

EN

Numatic

NX 300

NUC244NX

COMPACT SCRUBBER DRYER

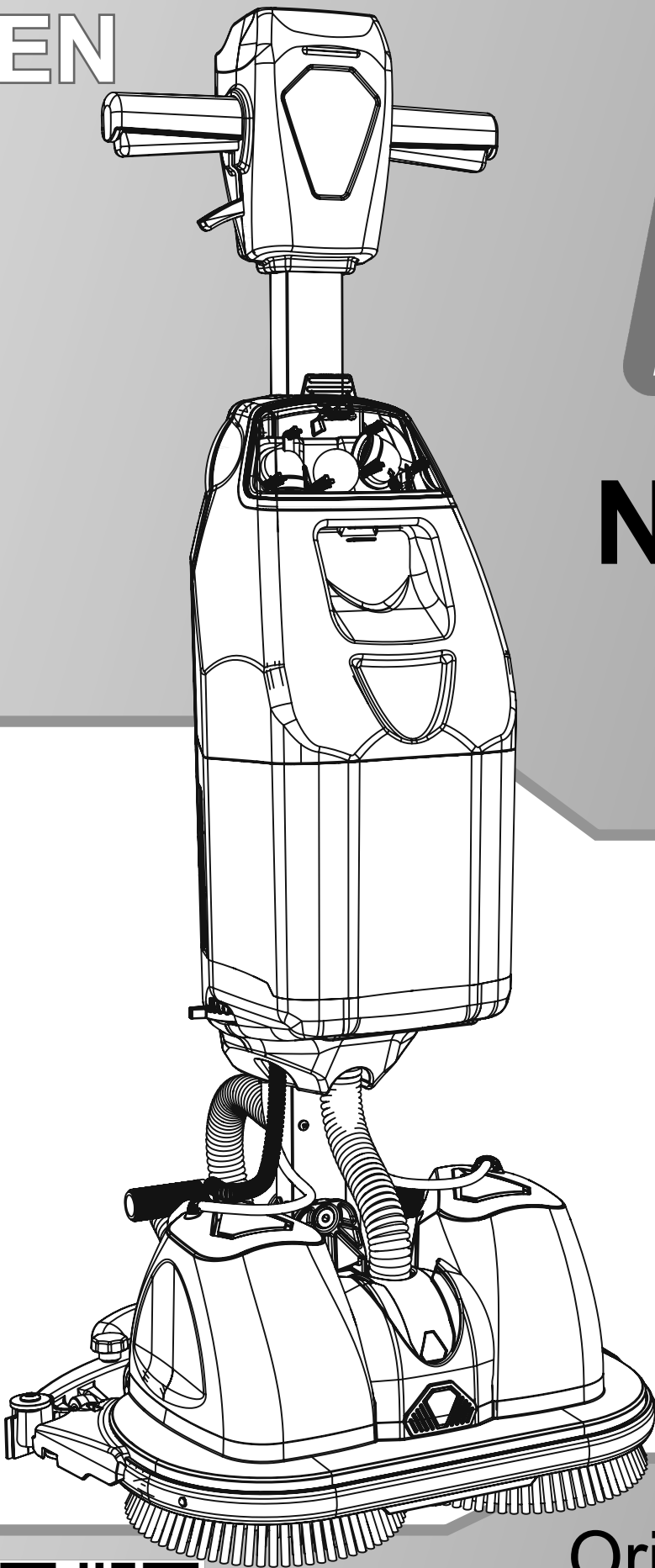

Original Instructions

CAUTION, Read instructions before using the machine
Keep for future reference



Numatic
Nu-Assist

Download on the
App Store

ANDROID APP ON
Google play



numatic.com

Index

Machine Overview	Pages 2 & 3
Control Panel Overview	Page 4
Quick Set up Guide	Pages 5 - 8
Brush fitting	Page 5
Floor tool and vacuum hose fitting.....	Page 5
Main tank assembly removal	Page 5
Clean water tank removal & filling	Page 6
Battery fitting & water flow setting	Page 7
Machine handle operation	Page 9
Storage & Transportation	Page 10
Regular maintenance	Page 11
Separator removal & cleaning	Page 11
Clean water tank outlet cleaning	Page 11
Float valve removal & cleaning	Page 12
Emptying Tanks	Page 12
Changing the floor-tool blades	Page 13
Refitting the floor-tool blades	Page 13
Battery removal & charging	Page 14
Removing the battery	Page 14
Battery Charging	Page 14
Twintec Maintenance	Page 14
Schematic Diagram	Page 14
Specifications	Page 15
Troubleshooting	Page 15
Rating Label / Personal Protective Equipment / Recycling	Page 16
Information for Scrubber Dryer	Page 17
Battery Information	Pages 18 - 21
Recommended Spare Parts	Page 21
EU Declaration Document	Page 22
Warranty	Page 23
Company Address	Page 24

**PLEASE READ
BEFORE COMMENCING
OPERATION.
KEEP FOR FUTURE REFERENCE**

**After the removal of all the packaging,
carefully open and check the contents**

- Owner Manual
- Battery Charger & Lead
 - Battery Pack
- Scrub Brushes x 2
- Squeegee Assembly

Machine Overview	
1	Operator control panel
2	Triggers
3	Waste-water tank
4	Clean-water tank
5	Brush deck
6	Squeegee blades
7	Clean-water flow adjustment taps
8	Clean-water filling / emptying cap
9	Floor-tool vacuum hose
10	Vacuum hose
11	Separator
12	Battery
13	Battery charger
14	Clean tank fill view windows
15	Storage lever
16	Floor-tool release lever
17	Transport / Storage wheels

In the event of a breakdown contact
your Numatic dealer or the
**Numatic Technical
helpline +44 (0)1460 269268**

Machine Overview

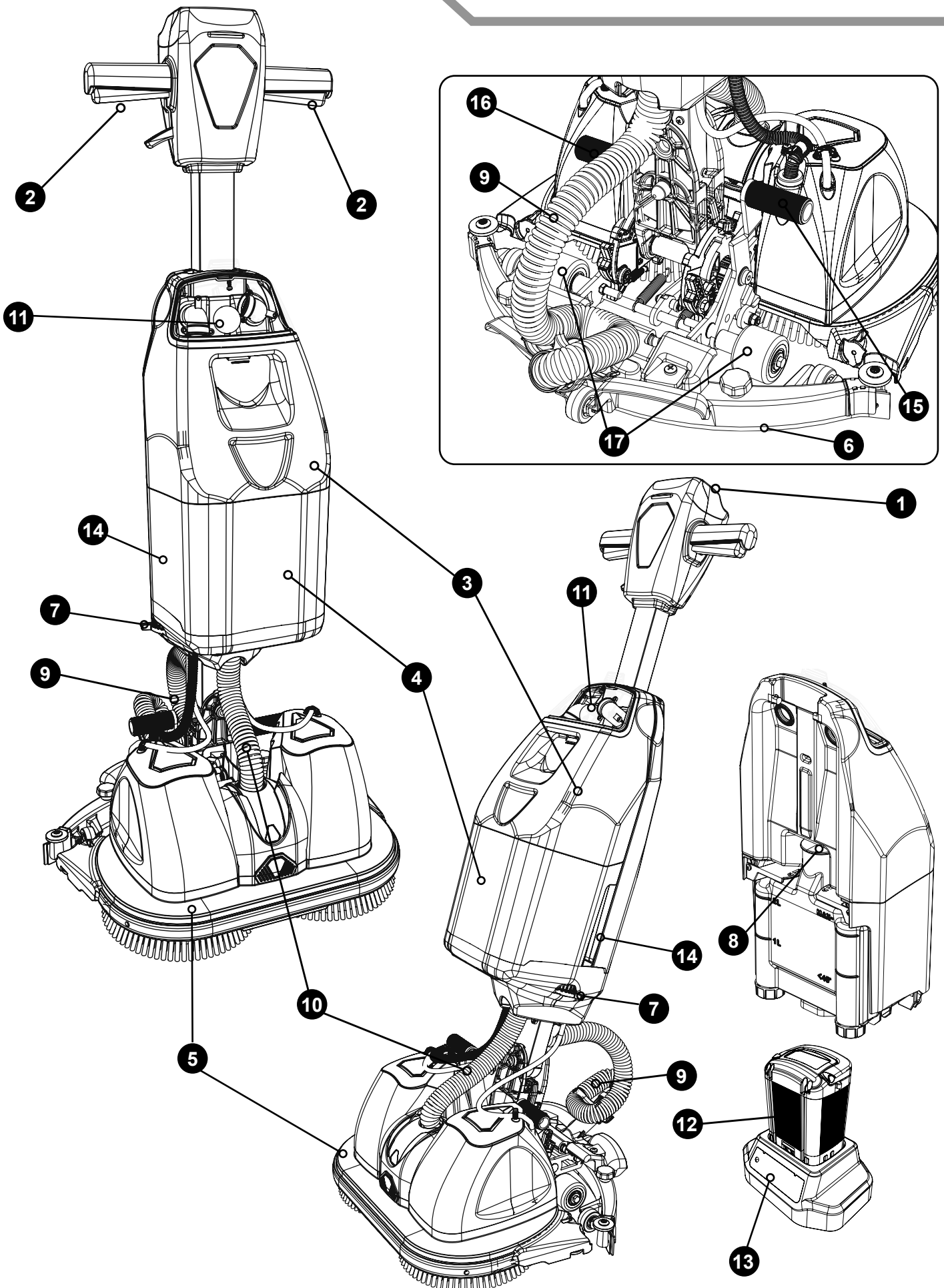

Control Panel Overview

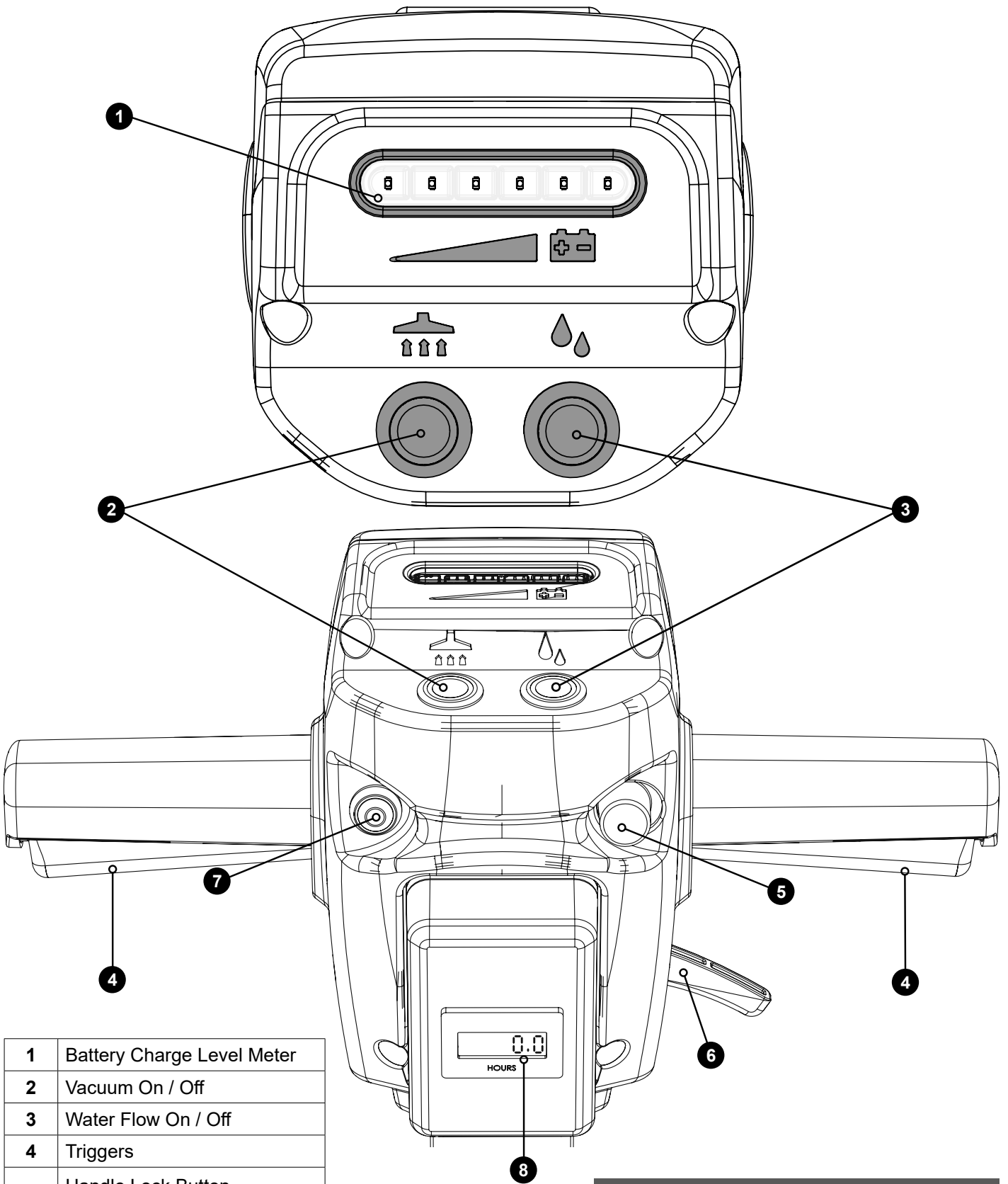

1	Battery Charge Level Meter
2	Vacuum On / Off
3	Water Flow On / Off
4	Triggers
5	Handle Lock Button (In the upright position)
6	Handle Release Lever
7	Start Button
8	Hours Meter

In the event of a breakdown contact
your Numatic dealer or the
Numatic Technical
helpline +44 (0)1460 269268

Quick Set-up Guide

CONTENTS

- Owner Manual
- Battery Charger & Lead
 - Battery Pack
- Scrub Brushes x 2
- Squeegee Assembly



PLEASE READ BEFORE COMMENCING ANY OPERATION AFTER THE REMOVAL OF ALL THE PACKAGING, CAREFULLY OPEN AND CHECK THE CONTENTS.



Brush Fitting

Make sure battery is removed before fitting or removing brushes.

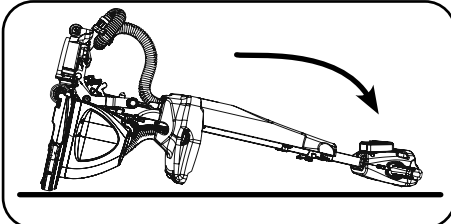

Make sure the handle is locked in upright position and storage wheels are retracted. Remove the tank assembly (and battery if fitted) gently lay machine on its front

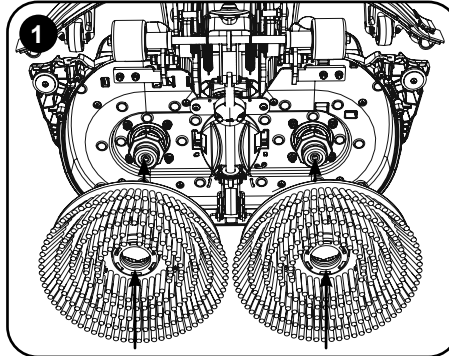

Push the brush / pad holder onto the brush motor mounts (1 & 2). Note: Gloves are recommended to be worn whilst fitting and removing the brushes.

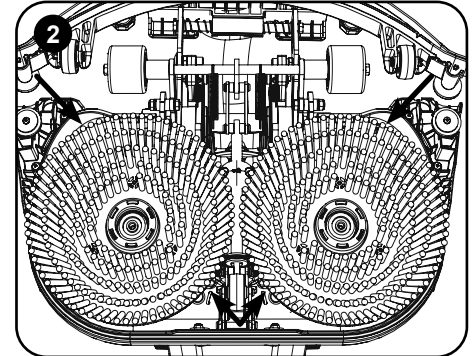

To remove the brushes, place your fingers behind the brush deck in locations shown and gently wiggle off.

Floor tool and vacuum hose fitting

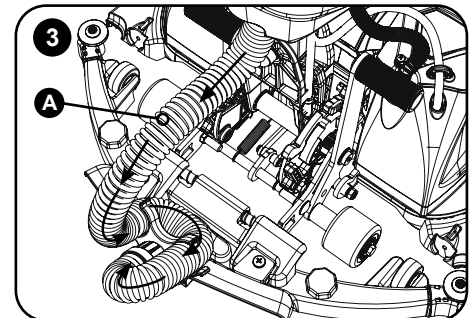
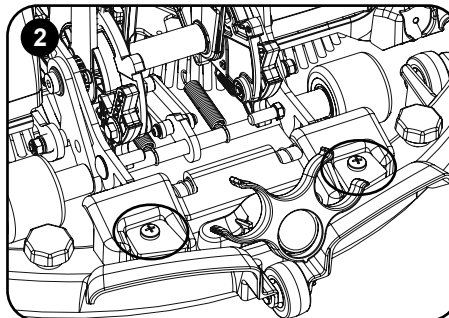
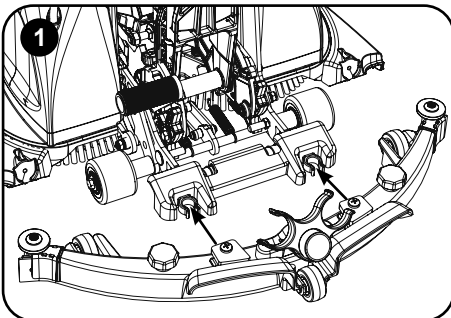

Push the floor tool carrier handle down and push the floor tool onto the retaining clips (1 & 2).

Take the hose and fit it into the hose retaining clips then push the open end securely over the centre fitting on the floor tool. Follow the arrows for the correct fit. Make sure part (A) of the hose stays loose and is not over stretched.

Main tank assembly removal

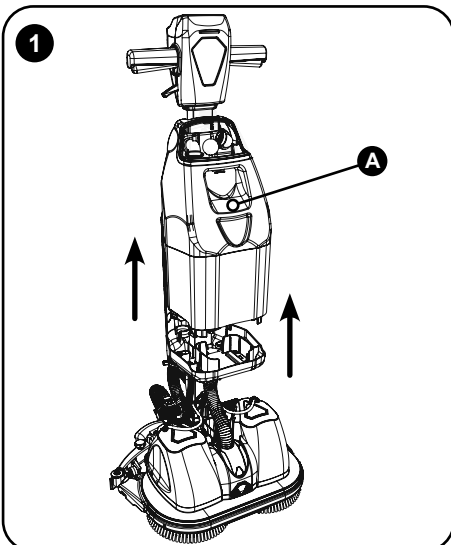

Remove the tank assembly from the front of the machine. Using the inset handle on the front of the tank assembly (A), lift the tank assembly up towards the main handle.

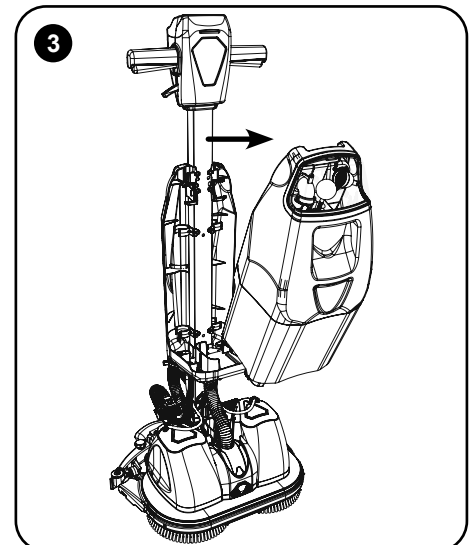
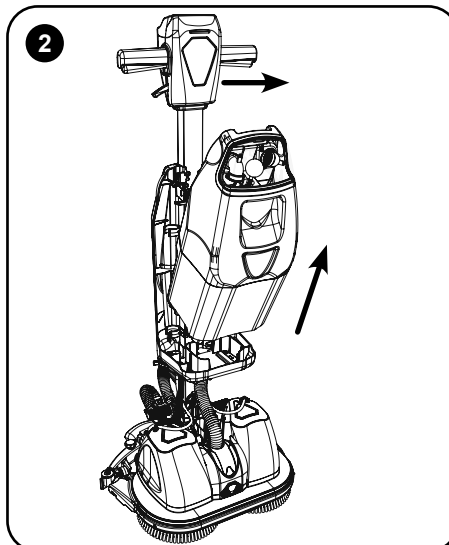

Lift and tilt the top of the tank assembly away from the handle as you remove. Place the tank assembly on a suitable surface in its upright/uppermost position.

Quick Set-up Guide

Clean water tank removal and filling

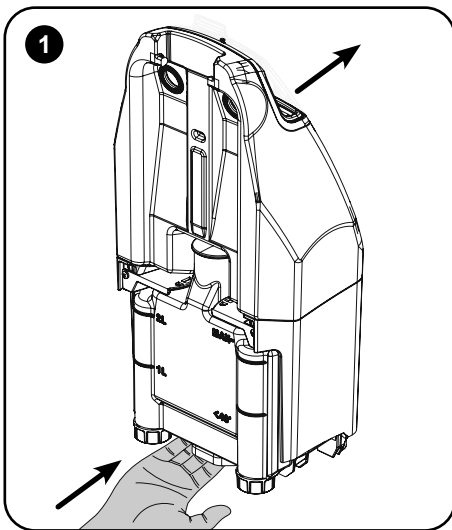

After lifting onto a suitable work surface, tilt the tank assembly slightly forward and slide your hand under the tank.

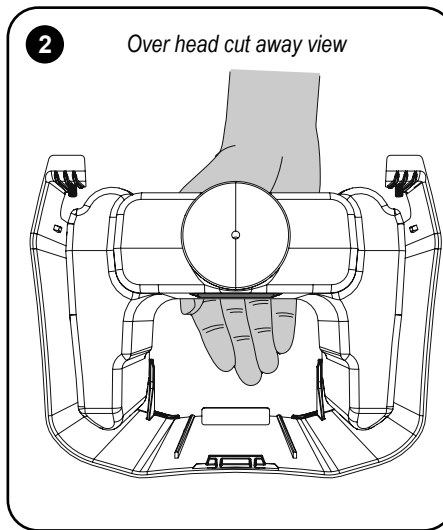

Slide your hand under the tank and curl your fingers up in the space in front of the tank, use your fingers to pop the tank out.

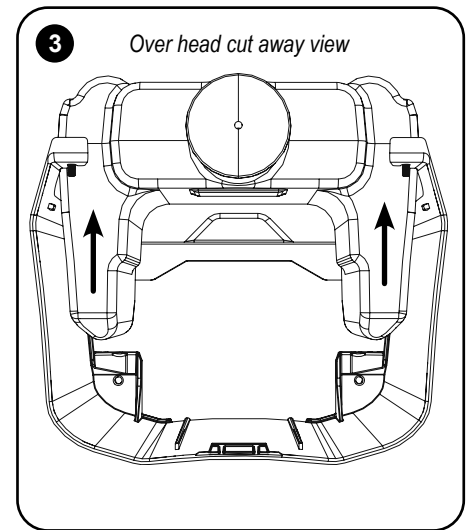

Remove the clean water tank from the main body of the tank holder.

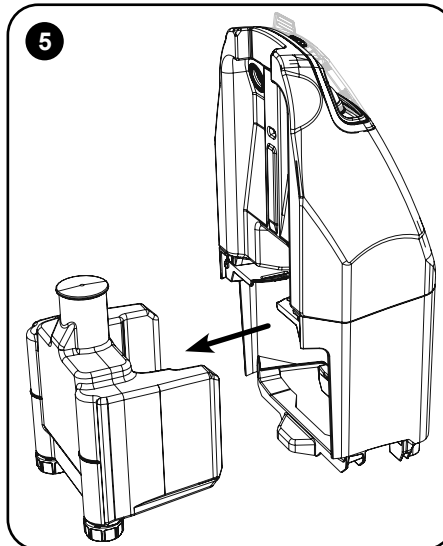
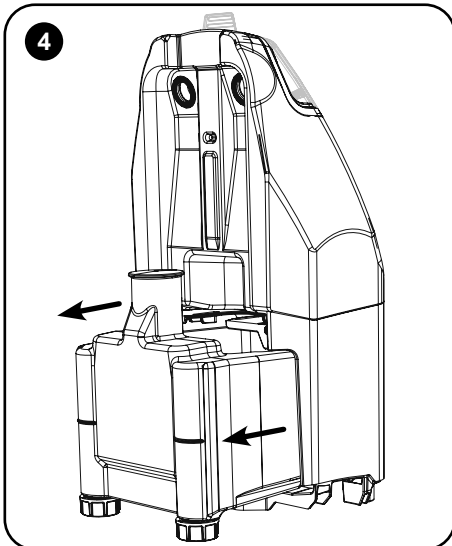

Remove the clean water tank from the main body of the tank holder (4&5). To fill remove the rubber stop from the filling neck. Note: There is a T piece keeping the rubber stop from being completely removed.

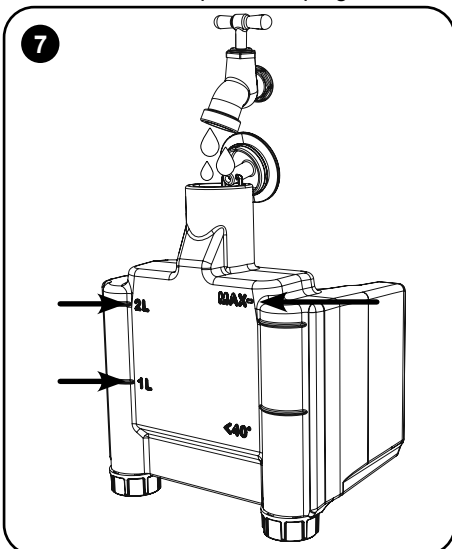
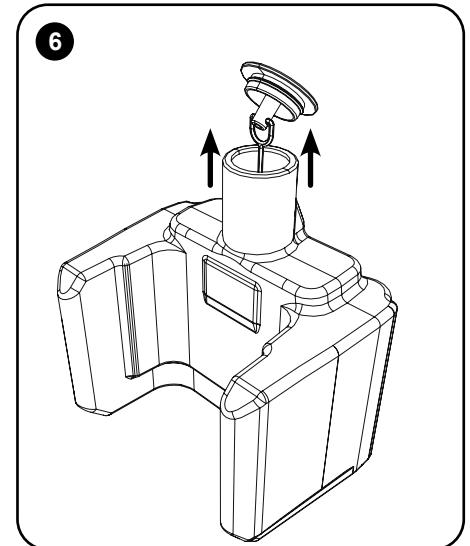

Pour in the chemical (follow chemical manufactures dilution rates). Only fill the tank to the MAX fill line with clean water using a tap, hose or suitable water container. DO NOT OVER FILL. Slide the tank back into the main tank body, make sure the front of the clean water tank is lifted to enter the recess (A).

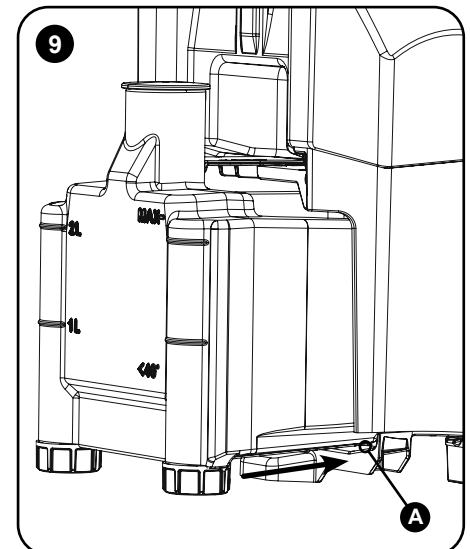
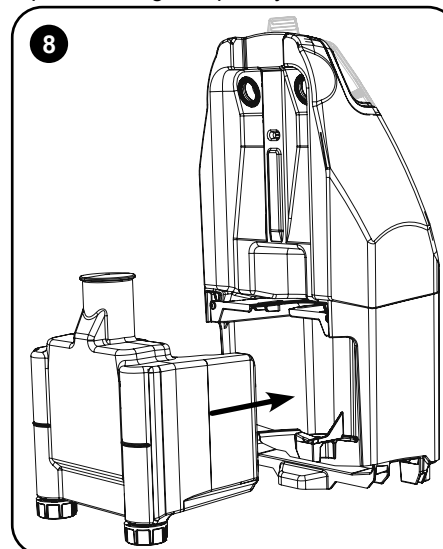

Push the tank all the way in until you hear it click, make sure it is securely fitted before fitting the tank assembly back on the machine.

Quick Set-up Guide

Battery fitting and water flow settings

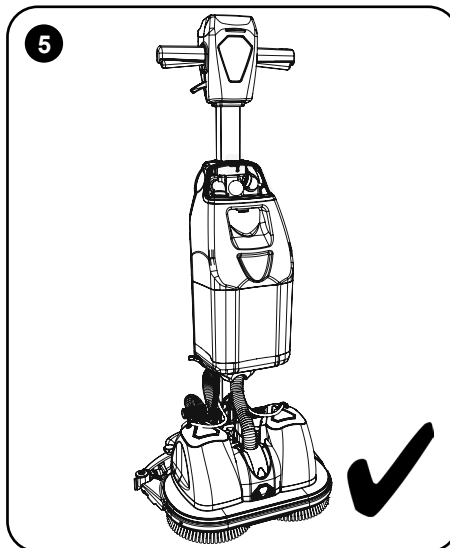
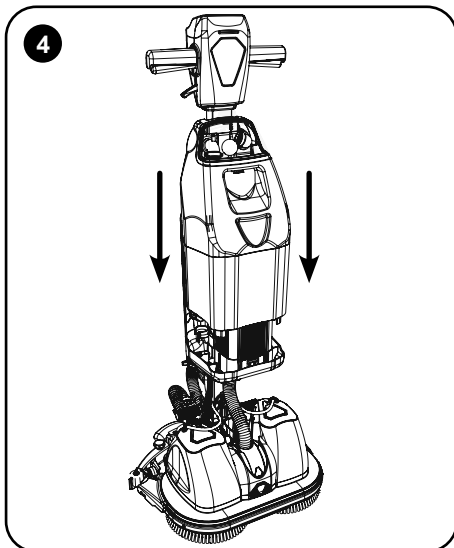
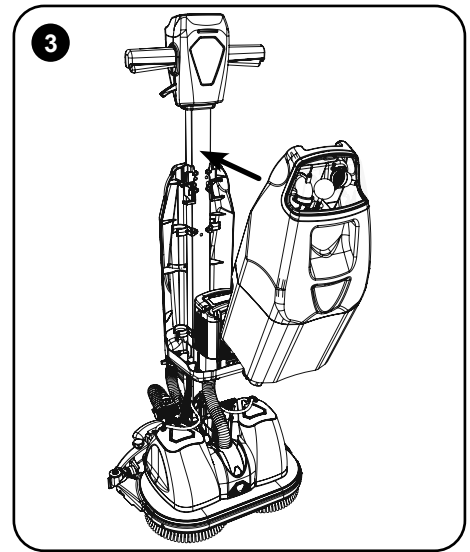
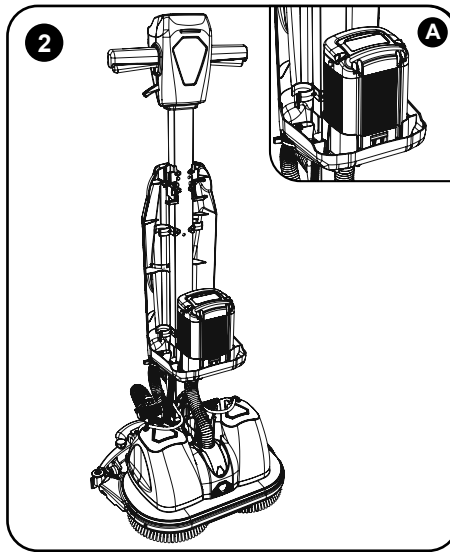
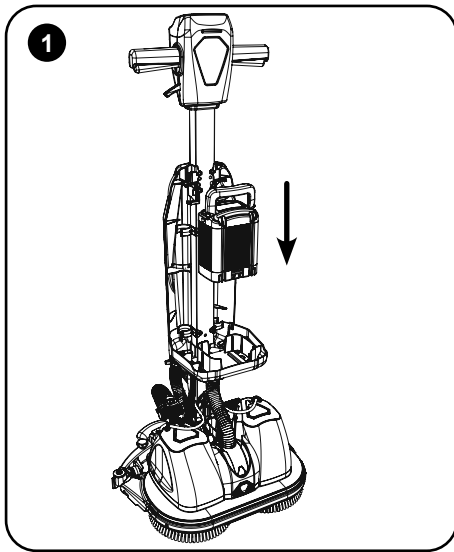

Lift the battery using the battery handle. Place the battery into the battery compartment ensuring it is securely in place and the orientation is correct (battery handle folds down towards the machine handle (A)).

Refit the main tank onto the machine.

Tilt the bottom of the tank towards the handle above the battery.

Line the tank up against the machine handle and lower the tank down. Make sure it is securely fitted.

Clean water tank full and fitted to the machine.

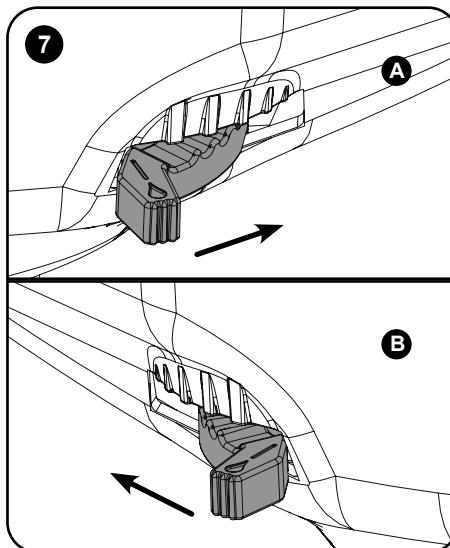
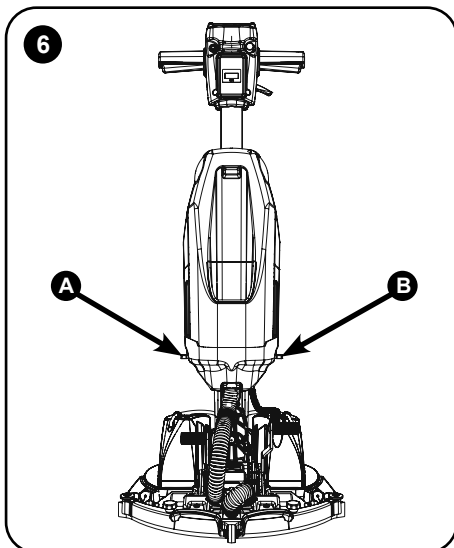

Located on the left and right side of the machine are the individual water taps for each brush.

Push the fluid control levers on the Left and Right of the machine to set the desired flow required, this will vary depending on what brush / pad and floor type the machine is being used on.

Note: On first use open the water taps fully and run the machine for a short period to purge the water flow then adjust taps to desired flow. Make sure each lever is set to the same position.

Quick Set-up Guide

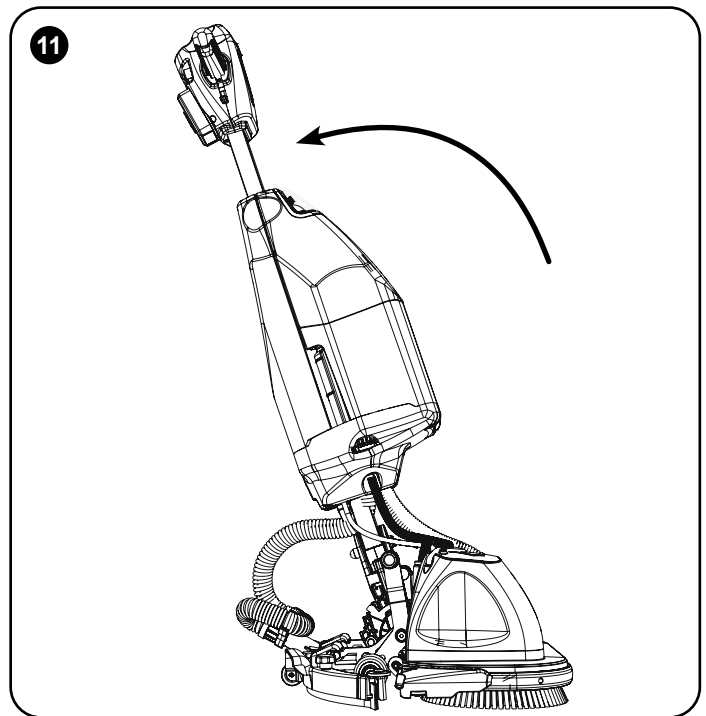
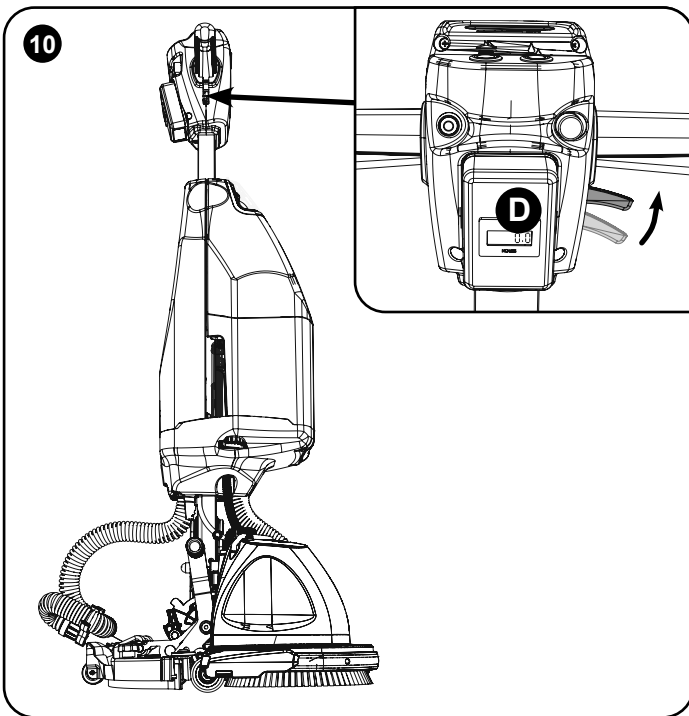
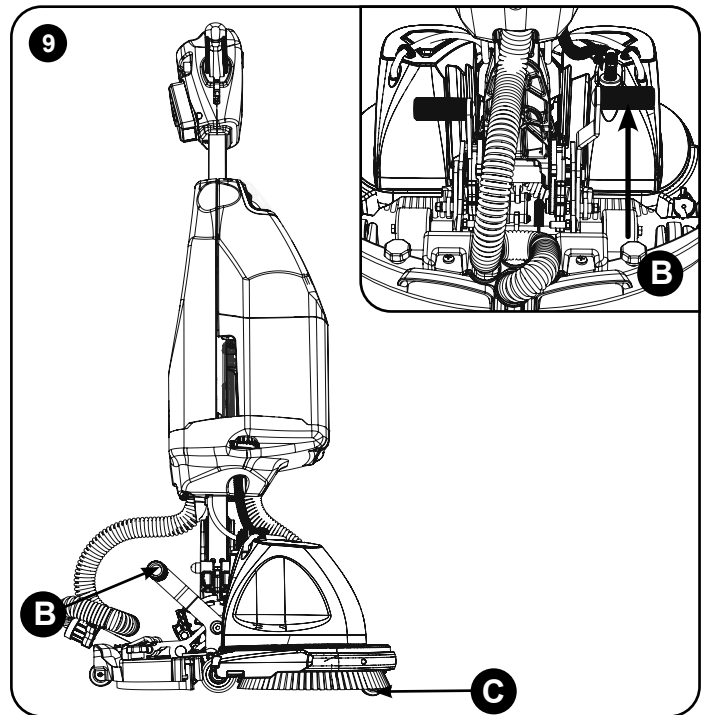
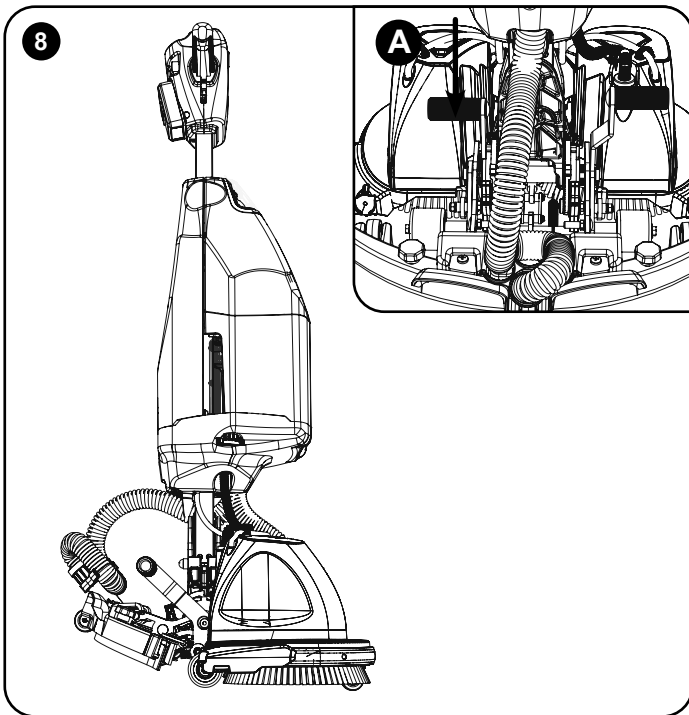

To lower the floor-tool, press down on the left foot pedal lever at the rear of the machine (8-A).

To lower the machine deck to the ground. Stand behind the machine, grip the handles. With your right foot push the right pedal forward (9-B). (By pushing lever the front support wheel retracts under the deck (9-C)).

Pull the small lever on the right hand side of the handle upwards (10-D) and then pull the handle backwards (11).

To raise the floor-tool (for over-scrubbing without picking up water) use the toecap locations to the rear of the floor-tool (E or F).

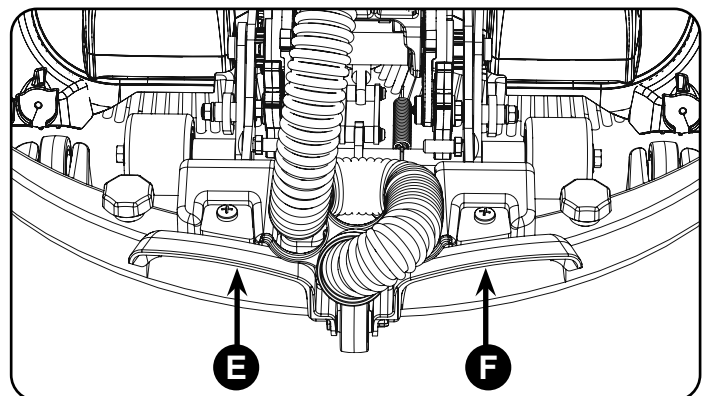

Machine Handle Operation

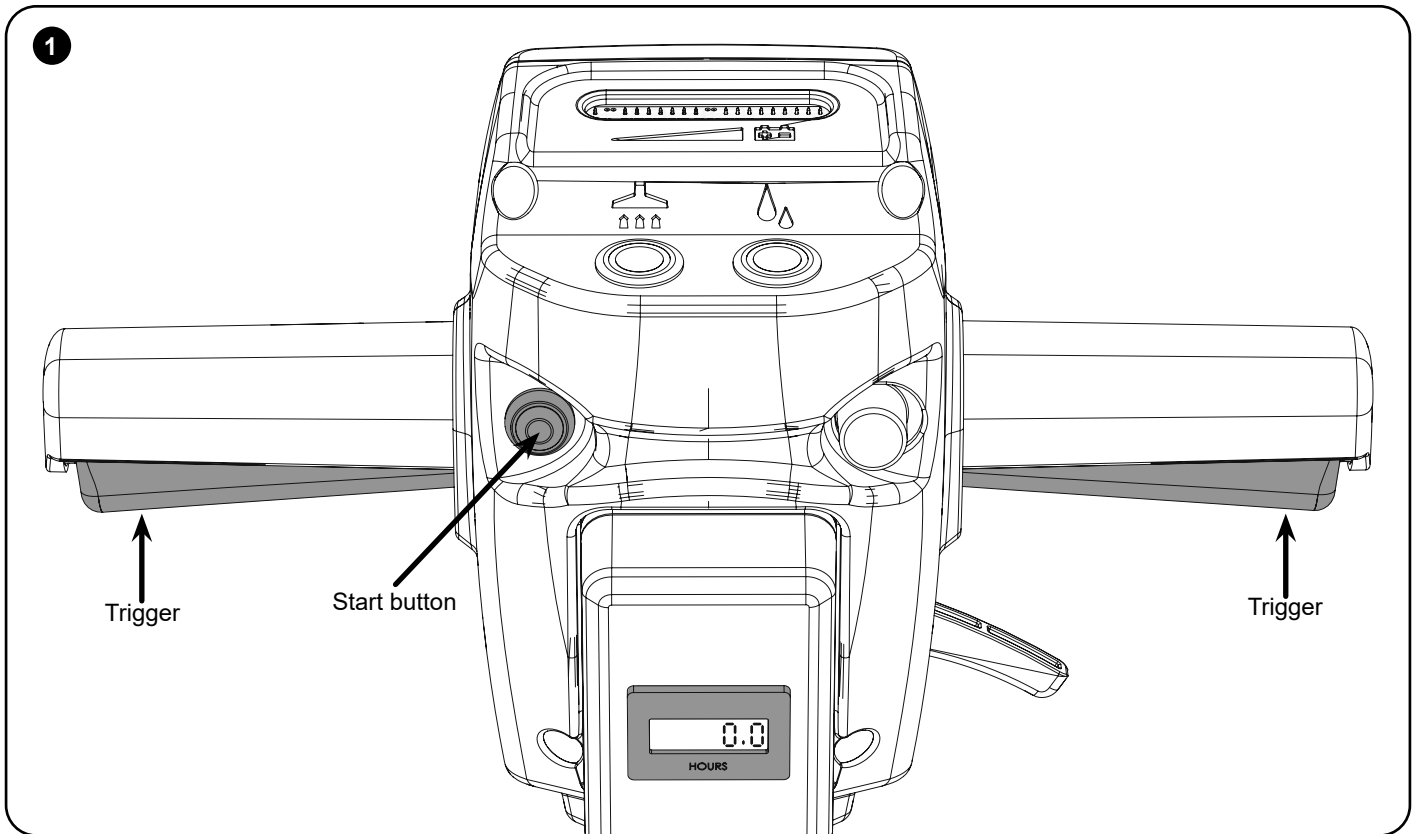

To start the machine pull one or both triggers in and press the start button, this will start the brushes spinning and the battery power indicator will illuminate to show the power level. This will also cause the hours meter to start counting up, recording machine usage, indicated by the flashing dot on the display. The hours meter display will always show the total hours even if the battery is removed from the product.

HOURS METER ONLY RECORDS WHEN BRUSHES ARE SPINNING

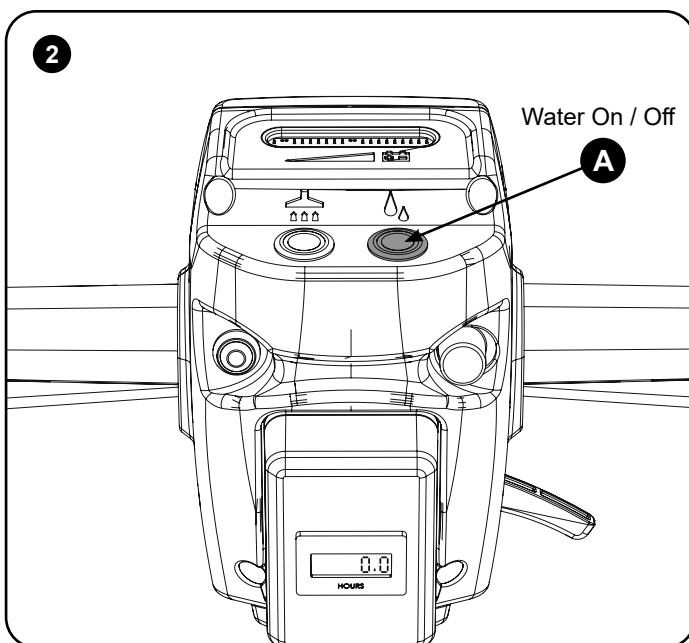

With either trigger pulled in press the water on button, this lights up blue to indicate it is on.

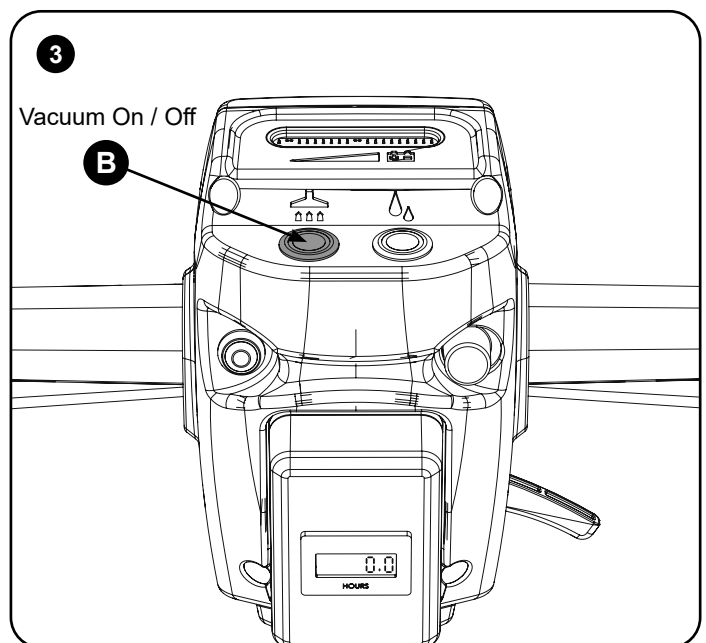

Press the vacuum on button, this lights up blue to indicate it is on and the vacuum starts. You are now ready to start cleaning.

Storage and Transport

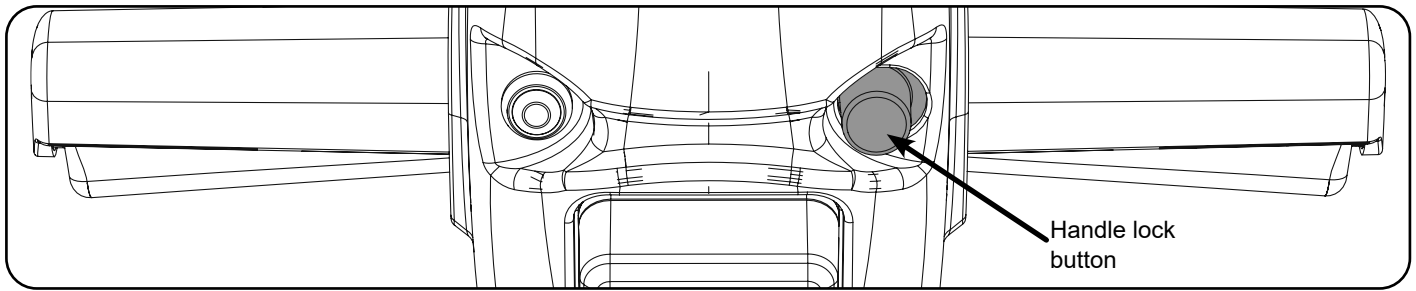

Make sure the handle is in the upright position and locked in place, push the handle lock button and locate handle in correct position.

Storage and Transport mode option 1

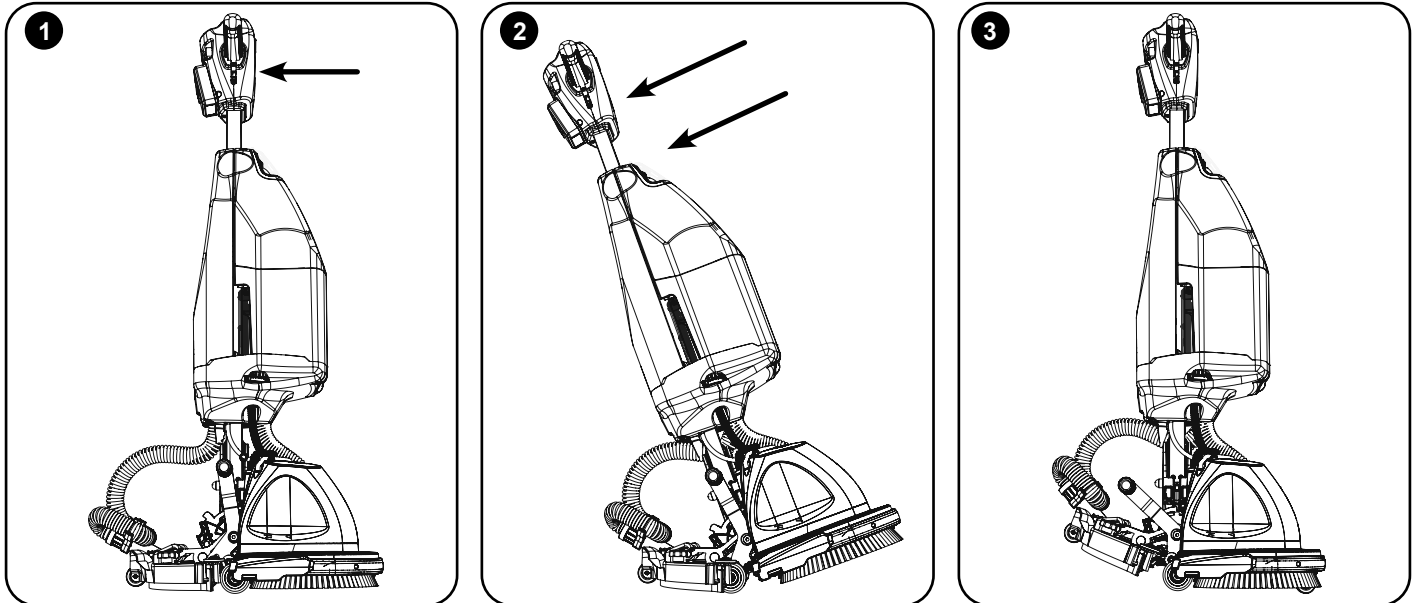

To put the machine into storage mode start with the handle locked in the upright position and the floor-tool down (1), pull the handle backwards until the floor-tool moves up and the transport wheels click out into position the front support wheel is deployed (2). Rest the machine back onto the transport wheels (3). (no button or lever action is required). Note: Do not let go of the handle.

Storage and Transport mode option 2

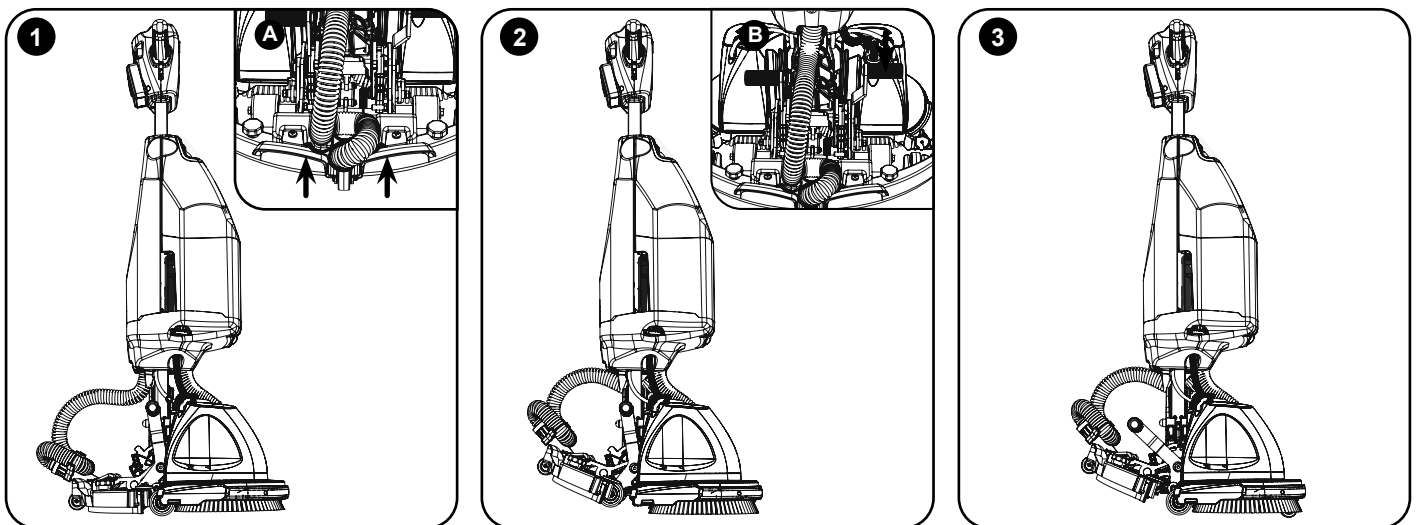

To raise the floor-tool use the toecap locations to the rear of the floor-tool and lift up (A). To raise the machine deck off the ground. Stand behind the machine, grip the handle. With your right foot push the right pedal down (B) while pulling the machine backwards until the storage wheels click into position and the front support wheel extends.



**MAKE SURE THE HANDLE IS LOCKED IN THE UPRIGHT POSITION
BEFORE LETTING GO OF THE HANDLE.**



Regular Maintenance

Separator removal and cleaning

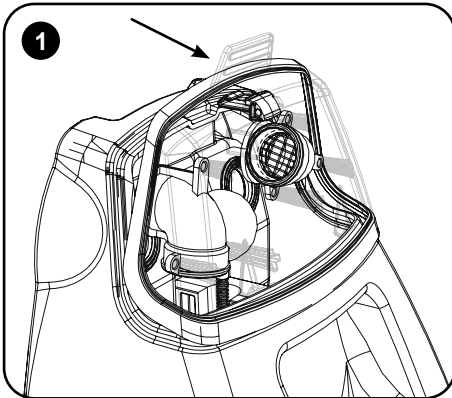

1 Using thumb and index finger grip the tab of the separator and pull forwards.

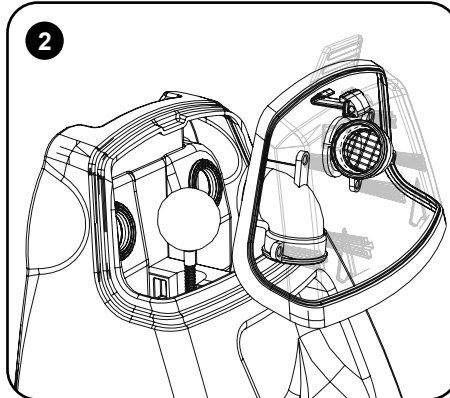

2 Lift the separator away from the tank.

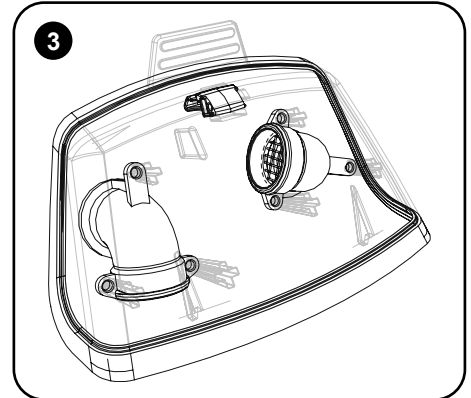

3 Take the separator to a suitable cleaning station.

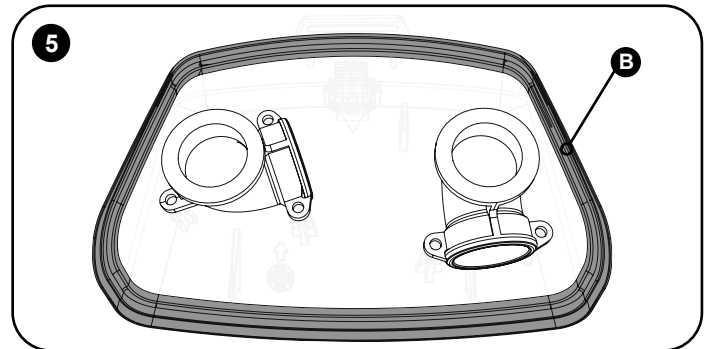
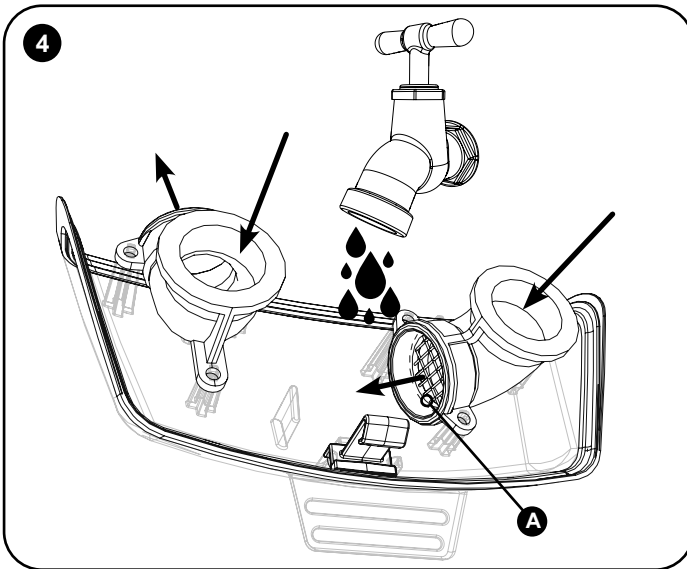

4 Once the separator has been removed, wash thoroughly under a tap making sure to run water through the tubes and to clean the grid filter (A).
5 Once clean thoroughly check the rubber seal for any damage or cracks (B).
If any damage or cracks are found on the rubber seal replace the separator. Failure to replace could cause loss in suction and machine performance.

Clean water tank outlets

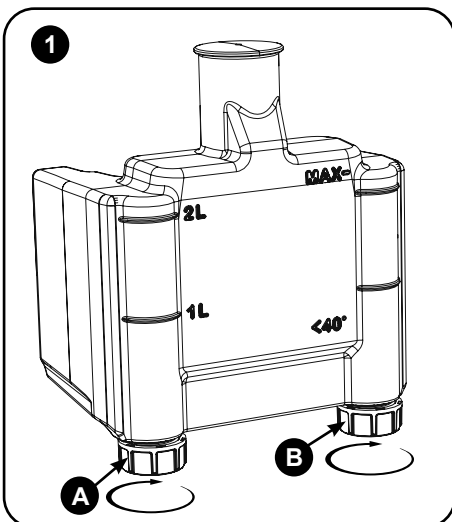

1 Make sure the clean water tank is empty. Unscrew the two clean water outlets, A and B.

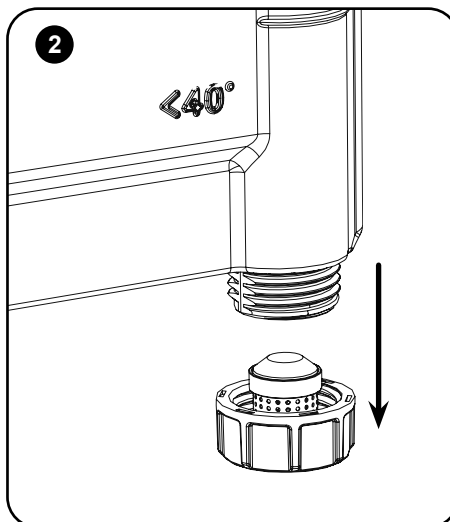

2 Remove the clean water outlets from the clean water tank.

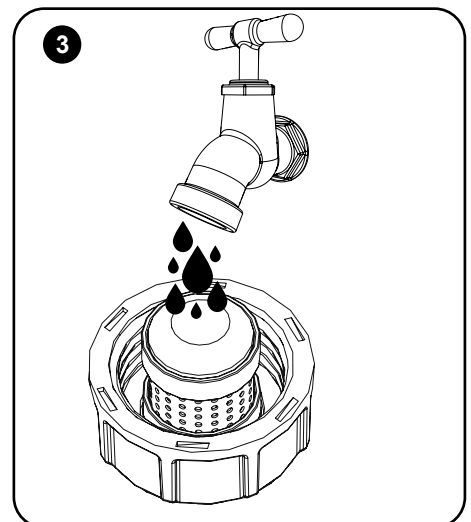

3 Wash the clean water outlets thoroughly under a tap, make sure the filter is clean with no blockages. Check for any damage (if any damage is found replace the clean water outlets).

Regular Maintenance

Float valve removal and cleaning

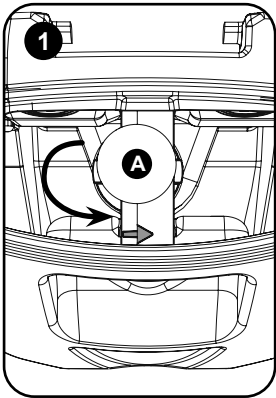

To remove the float valve twist the red retainer clip in the direction shown by the arrow on the retainer clip.

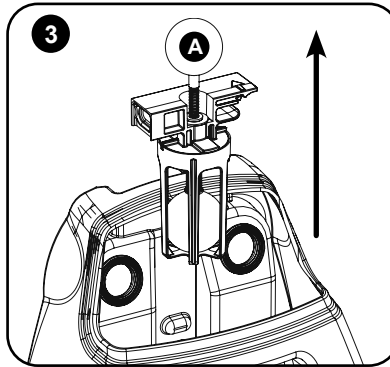
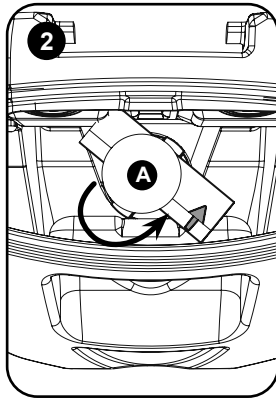

Lift the float valve from the tank, wash and inspect for damage.

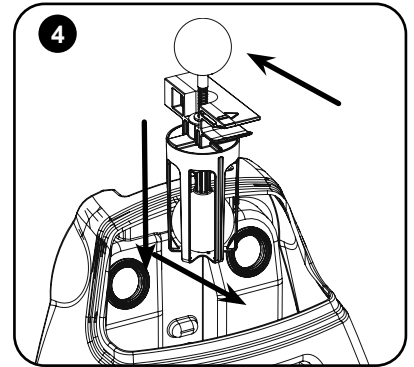

Place the float valve back down into the tank.

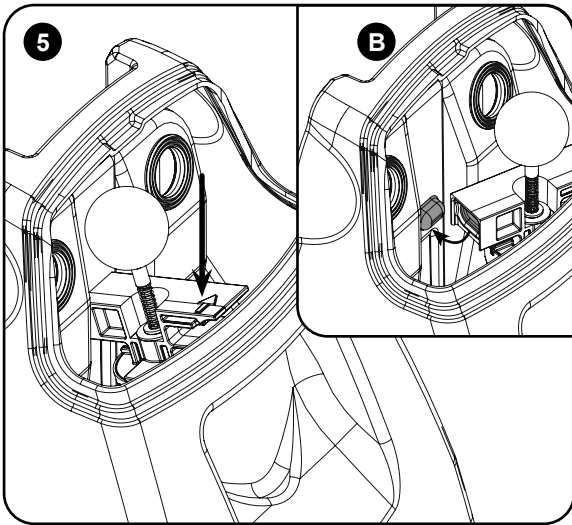

Tilt forwards at a slight angle making sure the protruding nub fits into the recess on the float valve (B). Press down firmly on the arrow and the float valve will click into place.

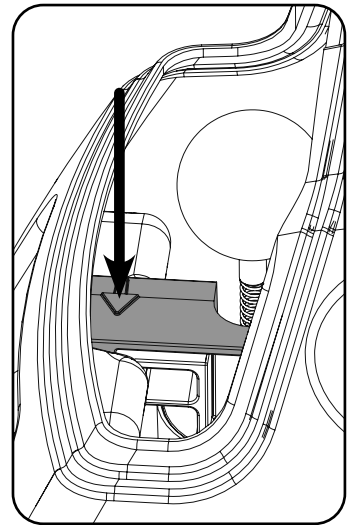
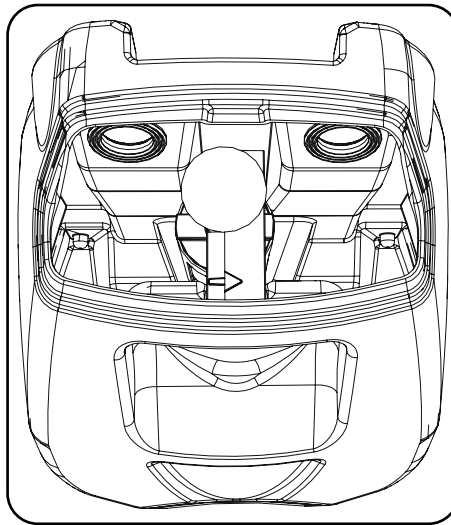

WARNING! DO NOT PULL ON THE FLOAT BALL (A)
PULLING ON THE FLOAT BALL WILL CAUSE IT TO BREAK AND THE VACUUM SHUT OFF WILL FAIL.



Emptying tanks

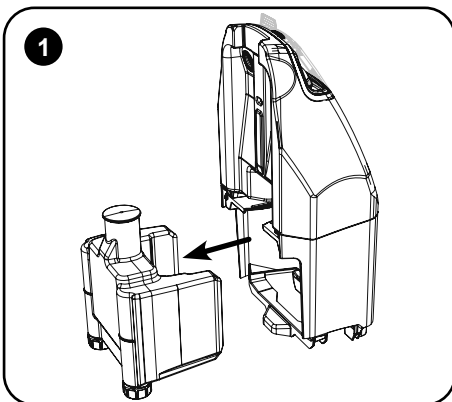

When finished using the machine it is good practise to empty and clean the tanks of the machine.

To do this firstly remove the tank assembly from the machine (see set up),

1. Remove the clean water tank from the main tank body and empty.

2. Remove the separator from the tank.

3. Pick up the tank, use the base shown as a handle, tip the contents into a suitable drain, rinse the tanks and repeat the emptying process. Refit the clean water tank and separator and place back onto the machine.

Note: If the machine is to be left for long periods between use, ensure the clean water tank is emptied.

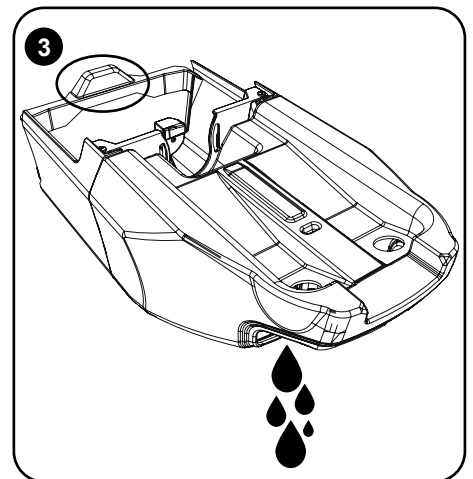
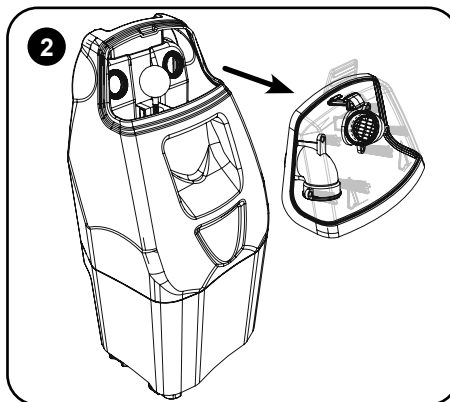

Changing the Floor Tool Blades



ALWAYS MAKE SURE THAT THE MACHINE IS SWITCHED OFF AND THE BATTERY IS REMOVED PRIOR TO ANY MAINTENANCE.

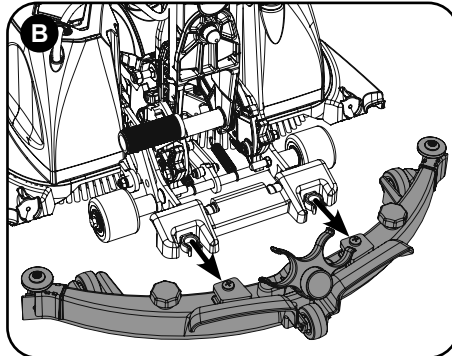
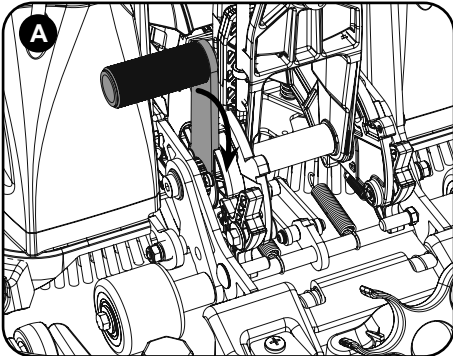

To change the floor-tool, firstly lower the floor-tool using the left side floor-tool lowering foot pedal (A).

Pull the floor-tool away from the machine (B).

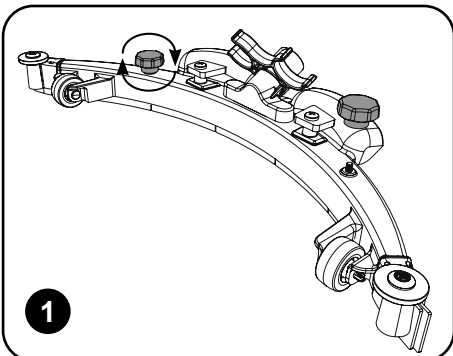

Unscrew the two knobs securing the blade holder (1).

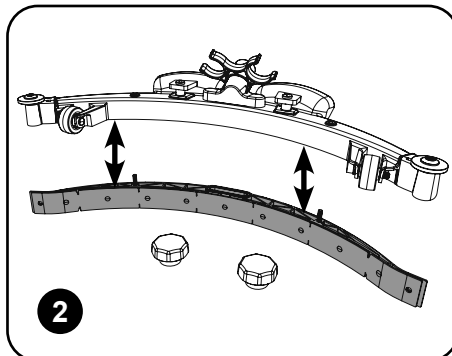

Remove the blade holder (2).

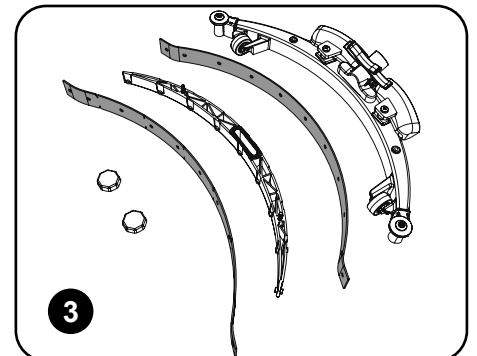

Replace the Squeegee blades using replacement blade set (Fig.3), fitting the blades on to the moulded location lugs.

Refitting the floor tool blades

Refit the blade holder, retain using the two outer knobs. Make sure the slotted blade goes to the front of the floor-tool.

Refit the floor-tool using the two central knobs to the floor-tool. Make sure the end holes on both squeegee blades are positioned correctly on 'T' shaped clip mouldings! (A)

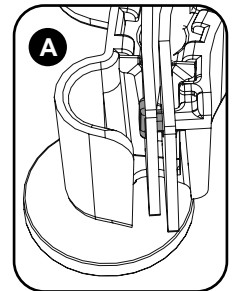
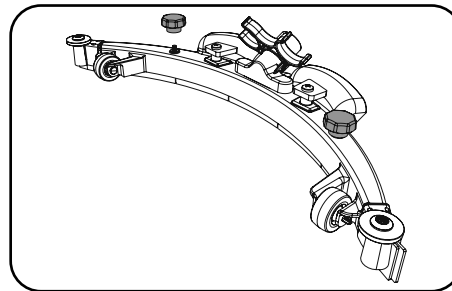

Floor Tool Overview

1. Retaining knobs x 2
2. Front blade (Slotted / Reversible)
3. Blade carrier
4. Rear blade
5. Floor tool main body

NOTE: The blades are designed to be reversible and rotated giving 4 usable surfaces (front, back, top and bottom), thus extending their useful working life).

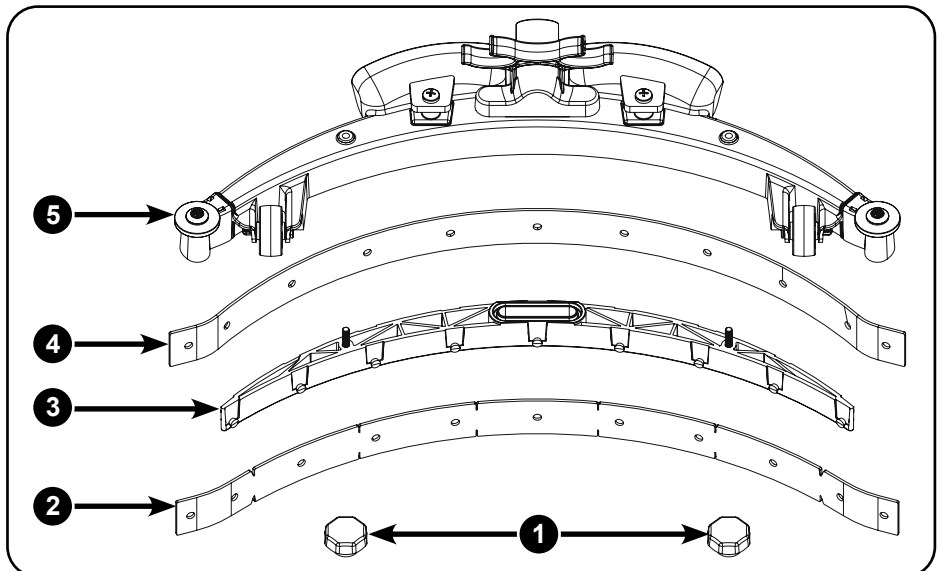

Battery Removal and Charging

Removing the battery

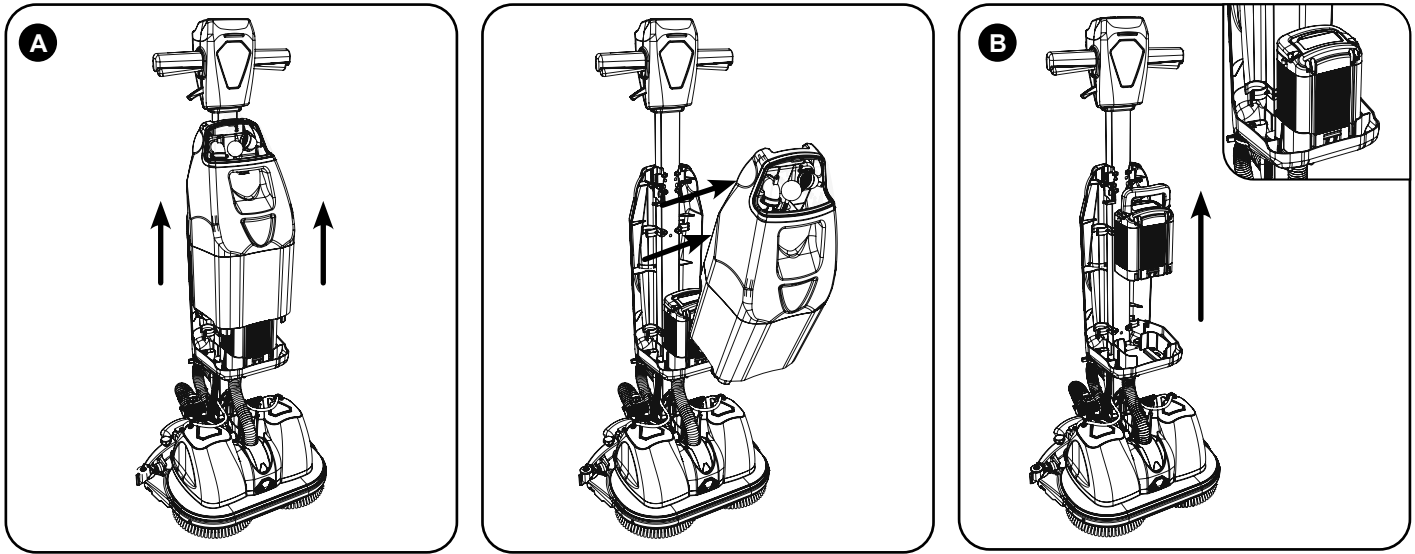

Remove the tank assembly from the front of the machine using the inset handle on the front of the tank assembly, lift the tank assembly straight up (A).

Pull the tank assembly from the machine and place on the ground.

The battery can then be lifted from the machine for storage or charging using the handle on the battery (B).

For information relating to the operation and charging of your battery please refer to the battery and charger original operating instructions.

Daily

Keep the machine clean.
Ensure brushes / pads / squeegee / filters are in good condition.
Check for any worn or damaged parts and replace immediately.
Drain and rinse dirty water tank after every use.

Weekly – as daily and –

Check brush / pad and deck skirt, wipe and rinse.
Check floor tool blades for wear and wipe clean.
Clean separator assembly including filter and check condition of seal.
Flush out system with clean water and clean filters.

**TwinTec
Maintenance**

Schematic Diagram

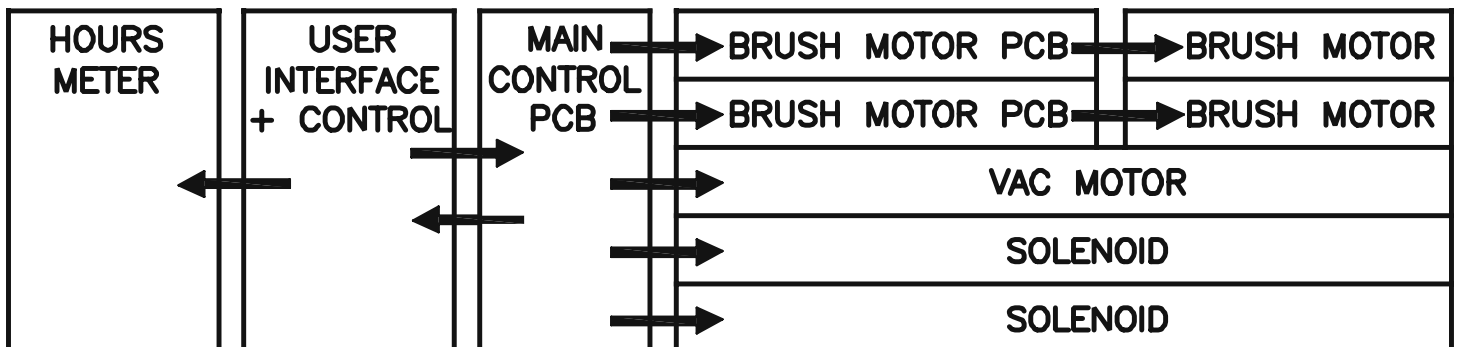

Specifications

Brush / Pad Weight (in cleaning mode)	Brush / Pad Pressure (in cleaning mode)	Cleaning Area	Brush Motor Power	Brush Speed	Brush / Pad Width	
12.5 kg	Brush 18.95 g/cm ² Pad 20.10 g/cm ²	1320 m ² /Hour @ 3 km/h	2 x 200W	140 rpm	2 x 220mm (440mm)	
Vac Motor Max Power	Clean Tank Capacity	Waste Tank Capacity	Water Ingress	Gross Weight (With liquid & battery)	Nett Weight (No liquid & No battery)	Rating
100W	2.2 L	3 L	IPX3	25.5 kg	21.3 kg	500W
*Run Time (Battery life)	*Recharge Time	Dimensions		Hand Arm Vibration	Sound Pressure (LpA) Uncertainty (KpA)	
*60-80 Min	*1 Hour (80%) *2 Hours (100%)	Width = 520 mm Length = 450 mm Height = 1140 mm - 1200 mm		≤ 2.5 m/s ²	≤ 70 dB(A) ±0.5 dB	
*Run and Recharge times may vary dependent on ambient temperature.						

Trouble Shooting

PROBLEM	CAUSE	SOLUTION
Machine will not operate	Battery not connected Low battery charge	Connect battery (page 7) Charge battery (page 14)
Vacuum will not operate	Vacuum not turned on	Turn on vacuum (page 9)
Poor water pick-up	Waste-water tank full Clogged / blocked squeegee hose Loose hose connections Separator filter clogged / blocked Poor separator seal Damaged separator seal Damaged / split vacuum hose Damaged floor-tool blades Low battery charge	Empty waste-water tank (page 12) Remove and clean (page 5) Push tight connections (page 5) Clean (page 11) Clean and refit (page 11) Replace (Contact Dealer) Replace (Contact Dealer) Replace (Contact Dealer) Recharge battery - see battery charger manual
No brush / scrub function	No brushes fitted Brush overloaded	Check and fit (page 5) Reset the machine and decrease the brush load
Little or no water flow	Clean-water tank empty Incorrect water flow setting Blocked clean water tank outlets	Fill clean-water tank (page 6) Adjust fluid control levers (page 7) Remove and clean (page 11)

Failure to rectify the problem or in the event of a breakdown contact your Numatic dealer or Numatic Technical helpline +44 (0)1460 269268

About the Machine

Rating Label	
1	Company Name & Address
2	Machine Description
3	Battery Voltage
4	Noise Emission
5	Hand Arm Vibration
6	Weight (ready to use)
7	Ingress Protection Rating
8	Gradient symbol
9	EU Importers info
10	Battery part number
11	Machine QR code
12	Approvals Mark
13	WEEE symbol
14	Part Number
15	Machine yr/wk Serial number
16	Numatic Support

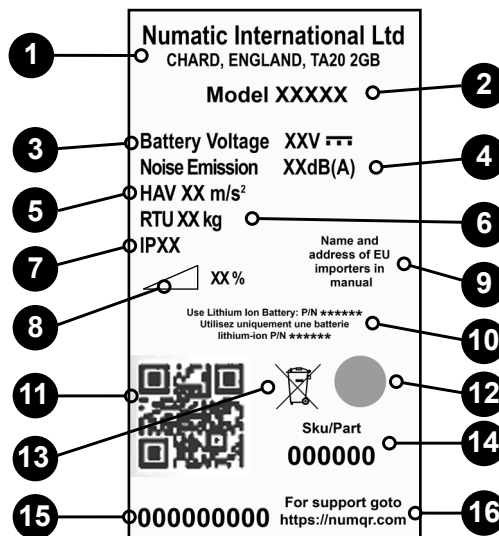

WEEE (Waste, Electrical and Electronic Equipment)

Scrubber dryer Accessories and packaging should be sorted for environmentally-friendly recycling. Only for EU countries.

Do not dispose of scrubber-dryer into household waste.

According to the European Directive 2012/19/EU on waste electrical electronic equipment and its incorporation into national law.

Scrubber-dryers that are no longer suitable for use must be separated, collected and sent for recovery in an environmentally-friendly manner.



PPE (Personal protective equipment) that may be required for certain operations.

Ear Protection	Safety Footwear	Head Protection	Safety Gloves	
Dust / Allergens Protection	Eye Protection	Protective Clothing	Hi-Vis Jacket	Caution Wet Floor Sign

NOTE: A risk assessment should be conducted to determine which PPE should be worn.

Safety Critical Component:

Charging Leads: HO5VV-F x 0.75mm² x 3 CORE
Battery Charger: 100 - 240 Volt

**In the event of a breakdown contact
your Numatic dealer or the
Numatic Technical
helpline +44 (0)1460 269268**

Information for Scrubber Dryer



READ MANUAL BEFORE USE

COMPONENT	INTERVAL	INSPECT FOR
Battery Charger Lead	DAILY	Scuffing, cracks, splits, conductors showing
Brushes	DAILY	Bristle damage, wear, drive collar wear
Squeegee Blade	BEFORE EACH USE	Wear, cracks, splits
Filters	BEFORE EACH USE	Clogging and debris retention
Tanks	AFTER EACH USE	Rinse dirty water tank after use



As with all electrical equipment care and attention must be exercised at all times during its use, in addition to ensuring that routine and preventative maintenance is carried out periodically in order to ensure its safe operation. Operators shall be adequately instructed on the use of these machines.

WARNING

Failure to carry out maintenance as necessary, including the replacement of parts to the correct standard could render this equipment unsafe and the manufacturer can accept no responsibility or liability in this respect.

When ordering spare parts always quote the Model Number / Serial Number specified on the Rating Plate.

Warning do not use on slopes exceeding 2%.

This machine is not intended for use by persons (including children) with reduced physical, sensory or mental capabilities, or lack of experience and knowledge.

Children should be supervised to ensure that they do not play with the appliance.

Only use brushes provided with the appliance or those specified in the instruction manual.

The use of other brushes may impair safety.

A full range of brushes and accessories are available for this product.

Only use brushes or pads which are suitable for the correct operation of the machine for the specific task being performed.

It is essential that this equipment is correctly assembled and operated in accordance with current safety regulations.

When using the equipment always ensure that all necessary precautions are taken to guarantee the safety of the operator and any other persons who may be affected.

Wear non slip footwear when scrubbing. Use a respiratory mask in dusty environments.

When cleaning, servicing or maintaining the machine, replacing parts or converting to another function the battery should be removed.

Machines left unattended shall be secured against unintentional movement.

When detergents or other liquids are used, read the manufacturer's instructions.



CAUTION

This machine is not suitable for picking-up hazardous dust.
This machine is not to be stored outdoors or in wet conditions.
This machine is for indoor use only.

NOTES: This machine is intended for commercial use, for example in hotels, schools, hospitals, factories, shops, offices and rental businesses. This product meets the requirements of IEC 60335-2-72



DO

- Ensure only competent persons unpack / assemble the machine.
- Keep your machine clean.
- Keep your brushes in good condition.
- Replace any worn or damaged parts immediately.
- Ensure that the work area is clear of obstructions and / or people.
- Ensure that the working area is well illuminated.
- Pre-sweep the area to be cleaned.



DON'T

- Use steam cleaners or pressure washers to clean the machine or use in the rain.
- Allow any inexperienced repairs. Call the experts.
- Allow the machine to be used by inexperienced or unauthorised operators or without appropriate training.
- Use the machine without the solution tanks properly positioned on the machine, as shown in the instructions.
- Expect the machine to provide trouble-free, reliable operation unless maintained correctly.
- Allow water solutions to ingress to the battery.
- Lift or pull the machine by any of the operating triggers, use the main handle.

Numatic Lithium-ion Rechargeable Battery

36V | 8400mAh | 300Wh | 2.06KG | 10INR19/65-3



It is important that you observe the following information and warnings!

Emergency Contact Information		
Address:	CBAK BATTERY HEADQUARTERS Shenzhen BAK ENERGY Co. LTD, 2603A BAK Tech Bldg, 9th Keyan Rd, Hi-tech Park, Nanshan Dist, Shenzhen City, China	NUMATIC INTERNATIONAL LTD Millfield Road, Chard, Somerset, TA20 2GB, UK
Tel:	0086-755-83283710	0044-146-068600
Fax:	0086-755-8328649	0044-146-068458
www.numatic.com www.numatic.de www.numatic.ch www.numatic.fr www.numatic.nl www.numatic.co.za www.numatic.pt www.numatic.es www.numatic.it www.numatic.dk		

1. DEFECTIVE BATTERIES

1. If a customer wishes to return a battery to a supplier, then collection of the battery must be arranged by the supplier; however, **Faulty batteries must not be returned through the postal system or by courier.**
2. If on return to a supplier, OR at a customer base, a suspected defective battery shows any signs of impact damage, distortion, blistering, loose parts, liquid ingress or leakage then on no account should it be offered for condition checking. It must be considered defective and the procedures described from item 9 below should be followed.
3. If, on return to a supplier, OR at a customer base, a suspected defective battery, that shows No signs of impact damage, distortion, blistering, loose parts, liquid ingress or leakage, may be offered for condition checking with an appropriate battery condition checking device operated by a competent person.
4. If battery is subjected to any liquid ingress users should put the pack upright immediately, with the terminal face downwards.
5. If checking shows the battery to be defective then the procedures described from item 9 below should be followed.
6. If on checking the battery is found to be operational then a single recharge cycle under observation can be attempted with the appropriate Numatic charger.
7. If the battery recharges correctly on this single recharge cycle then it can be deemed a good battery.
8. If the battery fails to recharge correctly on this single recharge cycle then it must be deemed a defective battery and the procedures described from item 9 below should be followed. **On no account must any further attempt to recharge be made. A defective battery should not be stored inside buildings on any account.**
9. The defective battery should be discharged by placing it in a container of salt water located in a well- ventilated area. This container should contain 25 litres minimum of saline water at a concentration of 15g common salt / litre of water. The container should have a closed locked lid but should not be sealed. The battery should be left fully immersed in the water to a depth of at least 100mm for at least 2 weeks. The water should be disposed of as hazardous waste when the discharge is complete.
10. The defective discharged battery can then be stored in a locked battery waste container which should be plastic or plastic lined and placed away from buildings and clearly signed as a defective battery container with appropriate warnings.
11. The batteries should then be sent for waste disposal according with your country's waste regulations.
12. Exhausted batteries are to be removed from the appliance and safely disposed of.

An example of a waste battery storage bin well away from buildings.

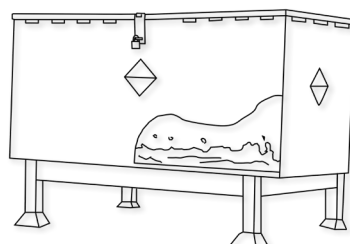

2. HANDLING AND STORAGE

DANGER!

Improper handling can lead to an explosion or ignite a fire!
Store batteries out of reach of children.

- Insert the battery in the appliance only when it is in use.
- Always remove the battery from the appliance for transport and when it is not in use.
- Storage temperature range: -10°C~55°C.
- Temperatures must not exceed 55°C.
- Relative humidity range: 45 to 80%.
- Optimum preservation of functionality: 15°C~25°C.

WARNING:

- Do not open the battery, disassemble it or allow it to fall from a substantial height.
- Protect the battery against short-circuiting – danger of explosion!
- Protect the battery against rain, do not immerse in liquids especially flammable liquids – danger of short-circuiting potential risk of fire or explosion. Follow defective battery disposal safety procedure. Insure the product is moved away from any combustible source.
- Protect the battery against direct sunlight, heat and fire.
- Do not incinerate the battery – danger of explosion!
- Do not use defective or deformed batteries.
- Use only original NUMATIC chargers to charge the battery.

STORAGE:

- If the appliance is to be stored unused for a long period, the batteries should be removed.
- Good batteries should be stored in a protected area away from sources of direct heat and sunlight and should be kept dry.
- The temperature should not exceed 55°C but preferably not be above 25°C to maintain good battery performance.
- Storage area should be of low humidity, non dusty and a non corrosive atmosphere.

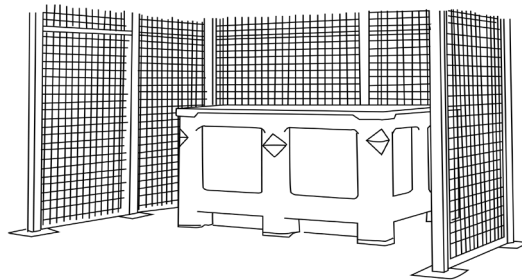

- An example of a well protected area with a cage to protect against accidental impact damage and with the batteries stored in a protective container to protect from heat, impact and accidental spillage of liquids.
- Care when handling / moving with forklift trucks or pallet trucks is needed at all times to avoid any physical damage to the batteries.
- If a good battery at any time is mishandled or subjected to any conditions that may damage it, as described in the battery instruction manual supplied, it must then be considered as defective and procedures followed from Item 1 of this document overleaf.

3. HAZARDS IDENTIFICATION

- Electrolyte may escape from damaged batteries. Avoid contact.
- Contact can cause skin irritation, burns and chemical burns.
- If liquid comes into contact with eyes, seek medical attention.
- Avoid inhaling any vapours formed or released – caustic.

4. FIRST AID MEASURES

In the event of contact with released electrolyte or electrolyte vapours:

- Eye contact – flush eyes for at least 15 minutes with plenty of clean water without rubbing and seek medical attention.
- Skin contact – wash affected areas of skin with plenty of water and soap; if irritation persists, seek medical attention.
- Inhalation – provide fresh air or administer oxygen immediately and seek medical attention.
- Ingestion – if electrolyte has been ingested, seek medical attention immediately.

Information for physicians:

- Contains caustic alkaline electrolytes in cells with lithium oxide, nickel oxide and cobalt/lithium manganese oxide cathodes – NO LITHIUM METAL OR LITHIUM ALLOYS.

5. FIRE FIGHTING MEASURES

- In case of fire – Keep clear of vapours and gases generated, take wind direction into consideration. If possible without danger, remove batteries from the vicinity of the fire. In principle, cooling or extinguishing with water is possible, but should only be done by trained personnel with sufficiently large quantities of water.
- If the hazard situation is unclear, extinguish only with ABC powder extinguishers (Class D extinguishers for fires involving metals are especially suitable).
- Fire fighters should only approach the fire wearing protective clothing and self-contained breathing apparatus.
- Once the fire has been extinguished, as a rule, the area should be monitored (fire watch) and cleaned up by trained and appropriately equipped personnel; fire residue should be contained and disposed of properly.

6. EXPOSURE CONTROLS, PERSONAL PROTECTION

Respiratory Protection:

- In case of battery venting, providing as much ventilation as possible. Avoid confined areas with venting batteries.
- Respiratory Protection is not necessary under conditions of normal use.

Ventilation:

- Not necessary under conditions of normal use.
- Protective Gloves:
- Not necessary under conditions of normal use.

Other Protective Clothing or Equipment:

- Not necessary under conditions of normal use.
- Personal Protection is recommended for venting batteries: Respiratory Protection, Protective Gloves, Protective Clothing and safety glass with side shields.

7. ACCIDENTAL RELEASE

Disposal – Wear protective gear, wipe up with absorbent textile and dispose of as hazardous waste at collection points for hazardous waste according to national regulations.

8. DO

- Use NUMATIC batteries only with NUMATIC appliances and charge them only using NUMATIC chargers.
- Charge battery before use.
- Store the battery out of the reach of children.
- Secure the appliance against unintentional start up – remove the battery from the appliance before transporting or storing the appliance.
- Protect from rain and liquid ingress
- Protect from direct sunlight, heat, and open flames.
- Be aware of the risk of terminals of the battery-operated appliance or battery being short circuited by metal objects.
- Follow the disposal advice of the manufacturer and any internal waste management guidance.
- Use and store the battery with-in temperature range (as shown in Temperature Range Table).

Warning: Use only with Numatic battery charger. The battery included in this product must only be charged by the Numatic Charger and docking system supplied with the product and in NO circumstances should an alternative non Numatic charger be used as there is risk severe damage and fire could result.

Note* "If batteries are subjected to temperatures beyond normal operating limits automatic shutdown will occur. Under these conditions allow the batteries to acclimatise at room temperature (18°C – 22°C) for several hours to allow the battery to wake up".

CHARGING	5°C~35°C
DISCHARGING	5°C~35°C
STORAGE OPTIMUM	15°C~25°C
STORAGE LIMIT	-10°C~55°C

9. DO NOT

- Throw battery into fire – risk of explosion!
- Charge or use a defective, damaged or deformed battery including batteries subjected to liquid ingress.
- Open, damage or drop the battery.
- Expose the battery to microwaves or high pressure.
- Immerse in fluids, especially flammable liquids.
- Insert objects in the battery's cooling slots.
- Bridge (short circuit) the battery terminals with metallic objects since this may damage the battery.
- Use metal containers for transporting batteries.
- Expose the appliance or battery to excessive temperatures.
- Expose the batteries to high temperatures including direct sunlight.
- Crush, break open or physically abuse the batteries or the equipment that contains them.
- Use modified or damaged batteries.

10. DISTRIBUTOR TAKE-BACK / DISPOSAL

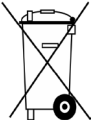

- On the basis of Battery Directive, the manufacturers take responsibility for financing collection, treatment and recycling of batteries used in devices. To this end, batteries must be handed over for disposal to the collection systems established for this under national law. Disposal of batteries together with household waste is prohibited; batteries must be collected separately according to type.
- Return the battery free of charge to your NUMATIC servicing dealer for disposal or hand it over to an appropriate public collection point.

11. CHARGING BATTERIES

- The charger is intended for use only on flat surfaces, place horizontally on floor or work surface. The charger is intended for use with the detachable power cord supplied, the power unit is capable of operating at different voltages without user adjustment. If the charger is damaged or does not charge anymore, please return to service centre.

Charging Procedure:

- Rechargeable batteries are to be removed from the appliance before being charged.
- Ensure the battery is fully inserted into the charger.
- Fit the mains power cord to charger and suitable power supply.

Please Note: If the battery is above its optimum charging temperature (due to ambient temperature or it if was recently discharged) the charger LED will illuminate on/off RED for a maximum of 40 minutes whilst the battery temperature falls to an acceptable level for charging to begin.

- The LED should show RED to indicate charging.
- Once fully charged the LED will show GREEN.
- If power is supplied to the charger with no battery fitted the LED will show GREEN to indicate STAND-BY status.

CAUTION!

- Protect the charger against moisture and store it in a dry place.
- Check the mains cord regularly for any sign of damage.
- Do not use damaged devices.
- If the mains cord of the charger is damaged, it must be replaced by an original NUMATIC INTERNATIONAL cord available from the manufacturer or service agent.

Battery Charger State of Charge Indicator (SoC)

No Battery Connected	Green Flashing Light
Charging	Red Light
80% Charged	Green Light
Error Condition / Battery Over Temperature	Red Flashing Light

12. WARRANTY

Lithium-Ion Battery Warranty

Warranty: Commercial Use

- Batteries are warranted (3 Year) providing all battery care rules are followed
- To claim warranty the following details must be supplied
 - Serial number of the machine (See page 16)
 - Battery date code
 - Date purchased
 - Proof of Purchase
 - Maintenance history and charging regime

Failure to use the correct Numatic charger will void your warranty.

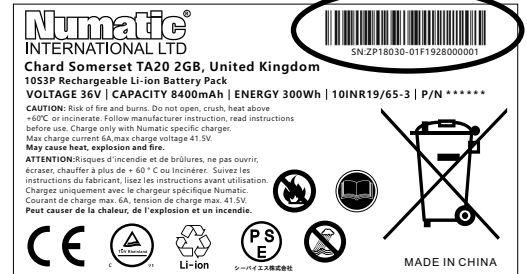

ZP19006-01FY192800001

Serial number
Week of production
Year of production

Spare Parts

Part No.	SPARES & ACCESSORIES	Part No.	SPARES & ACCESSORIES
911334	LITHIUM BATTERY CHARGER	912363	CHARGER CABLE (SOUTH AFRICAN)
912365	CHARGER CABLE (UK)	912360	CHARGER CABLE (AUSTRALIAN)
912361	CHARGER CABLE (EURO)	912362	CHARGER CABLE (NORTH AMERICAN)
912364	CHARGER CABLE (SWISS)		

Numatic International Warranty

Numatic International Limited warrant to the original purchaser that its products are free of defects in both material or workmanship for the period shown below:-

Homecare and Cleancare Vacuum cleaners.....	2 Years
Rotary Floor Machines.....	2 Years
Twintec Auto Scrubber Dryer.....	1 Year
Vario Ride-On Scrubber Dryer.....	1 Year / 1500 hours
Mopping, Compacts, Combi and Servocare Products.....	1 Year
Individual Accessories and Spare Parts.....	6 Months

Note: This warranty expressly excludes consumable parts such as carbon brushes, floor brushes, mops, batteries etc, that are considered replaceable from time to time during the normal working life of the machine.

Using non Numatic dustbags can be detrimental to both machine performance and life and may invalidate the Warranty.

- A. The warranty period commences from the date the goods are purchased.*
- B. All warranty claims must be processed through the Dealer from whom the equipment was purchased. The Dealer will co-operate with the purchaser throughout the warranty claims procedure and will arrange any necessary repairs using genuine Numatic parts.*
- C. If the original Dealer is no longer able to fulfil his obligations please contact Numatic International Limited with full details of the claim and proof of purchase so that this may be processed without delay.*
- D. Any warranty claim can only relate to the specific part that is proven to be at fault and for which a replacement will be supplied but cannot be extended to constitute a claim against the complete machine.*
- E. Numatic International will supply the Dealer with any warranty parts required, subject to the claim being validated, after return of the faulty items in accordance with Numatic International Limited's General Conditions of Sale.*
- F. Claims will not be accepted if they are the result of fair wear and tear, misuse or abuse of any kind.*
- G. No replacement will be given unless the appropriate evidence of the validity of the claim has been provided to the satisfaction of Numatic International Limited.*
- H. Numatic International Limited reserve the right to charge for any unnecessary work carried out as a result of an invalid claim.*
- I. No variation to this warranty may be made or implied by any member of Numatic International Limited or its Dealers unless such variation is in writing and authorised by the Company*

Numatic

Numatic International Limited. Chard, Somerset, TA20 2GB

Telephone: 01460 68600 Fax: 01460 68458

© Numatic International Limited

UKCA Declaration of Conformity	
Manufacturer:	Numatic International Limited Chard Somerset TA20 2GB www.numatic.co.uk
Product:	TTB244, NUC244
Description:	Floor Treatment - Walk Behind – Commercial - Battery
We, Numatic hereby declare under our sole responsibility, that the above-mentioned product(s) is/are in conformity with the following directives and standards.	
S.I. 2008: 1597	Supply of Machinery Regulations EN60335-1:2012 + AC:2014 + A11:2014 + A13:2017 + A15:2021 EN60335-2-72:2012 EN62233:2008
S.I. 2016: 1091	EMC Regulations EN55014-1:2017 + A11:2020 EN55014-2:1997 + A1:2001 + A2:2008
S.I. 2012: 3032	RoHS Regulations

Authorised Signatory: Mr. Matthew Coles

Position: Head of Technology

Numatic International Limited,
Chard,
Somerset, TA20 2GB, UK

Signed:  Date: 1st February 2024

EU, EC, EL, UE, ES: Declaration of Conformity Prohlášení o shodě Konformitätserklärung Overensstemmelseserklaring Declaración de conformidad Vastavusdeklaratsioon Declaração de conformidade	Deklaracija za съответствие Дηλώνση συμμόρφωσης Megfelelőségi nyilatkozat Dichiarazione di conformità Atihtična deklaracija Conformiteitsverklaring Samsvarserklaring Declaração de conformidade	Deklaracija zgodnosti Declaratie de conformitate Декларация о соответствии Forsikran om overensstemmelse Izjava o skladnosti Vastavustemmuksusavakutsus
Manufacturer: / Výrobce / Hersteller / Fabrikant / Fabricante / Toetija / Fabricant / Производитель / Кочевуководци / Gyártó / Fabricante / Gaminintojas / Fabrikant / Produzent / Fabricante / Producent / Producător / Производители / Tilverkere / Proizvajalca / Valmistaja:	Numatic International Limited Chard Somerset TA20 2GB www.numatic.co.uk	Numatic
Product: / Produkt / Produk / Produkto, Toode / Produit / /Produkt / Προϊόν / Термек / Prodotto / Produkto / Artikeli / Produkt / /Produtos / /Produkt / /Produkt / /Tovary / /Izdelka / Туоте:	TTB244, NUC244	Floor Treatment – Walk Behind – Commercial - Battery
Description: / Pops / Beschreibung / Beskrivelse / Descripción / Kirjeldus / La description / Описание / Περιγραφή / Leirás / Descripción / Apibudinimas / Omschrijving / Beskrivelse / Descrição / Opis / Descrione / Описание / Beskrivning / Opis / Kwiat:		

EN We, Numatic hereby declare under our sole responsibility, that the above-mentioned product(s) is/are in conformity with the following directives and standards.	BG Ние, Numatic С настоящото декларираме на свои лични отговорност, че посочените по-горе продукти е в съответствие със следните директиви и стандарти.	PT Nós, a Numatic declaramos, sob nossa exclusiva responsabilidade, que o produto acima mencionado está em conformidade com as diretivas e normas a seguir.
CS My, Numatic prohlašujeme na svou výlučnou odpovědnost, že výše uvedené výrobky je ve shodě s následujícími směrniciemi a normami.	EL Εγώ, η Numatic δηλώνω με αποκλειστική μου ευθύνη, ότι τα παραπάνω προϊόντα συμμορφώνονται με τις ακόλουθες οδηγίες και πρότυπα.	PL My, Numatic niniejszym oświadczamy z pełną odpowiedzialnością, że wyżej wymieniony produkt jest zgodny z następującymi dyrektywami i normami.
DE Wir, Numatic erklären in alleiniger Verantwortung, dass das oben genannte Produkt den folgenden Richtlinien und Normen entspricht.	HU Mi, Numatic kijelentjük, egyedül felelősséggel, hogy a fent említett termék megfelel az alábbi irányelveknek és szabványoknak.	RO Noi, Numatic Prin prezenta declarăm pe propria răspundere, că produsul mai sus menționat este în conformitate cu următoarele standarde și directive.
DA Vi, Numatic erklærer hermed under eget ansvar at ovennævnte produkt(er) er i overensstemmelse med følgende direktiver og standarder.	IT Noi, Numatic dichiariamo sotto la propria responsabilità, che il prodotto di cui sopra è conforme alle seguenti direttive e norme.	RU Мы, Нивматик оивим изьявляем под своим одговорноу, да нааеэвор произведо је у соовлау са следяиим директивама и стандардима.
ES Nosotras, Numatic declaramos bajo nuestra única responsabilidad que el producto antes mencionado está en conformidad con las siguientes directivas y normas.	LT Mes, "Numatic pareišku vienašališkos atsakomybės, kad pirmiau minėtas produktas atitinka šias direktyvas ir standartus.	SV Vi Numatic förklarar härmed under eget ansvar att ovan nämnda produkt överensstämmer med följande direktiv och normer.
ET Meie, Numatic käesolevaga kinnitame ja kanname ainuiskulust vastutust, et eespool nimetatud toode on kooskõlas järgmistele direktiividele ja	NL We verklaren Numatic hierbij op eigen verantwoordelijkheid, dat het bovengenoemde product voldoet aan de volgende richtlijnen en normen.	SL Mi, Numatic izjavljamo s polno odgovornostjo, da je zgoraj omenjeni izdelek v skladu z naslednjimi smernicami in standardi.
FR Numatic déclare sous notre seule responsabilité que le produit mentionné ci-dessus est conforme aux directives et normes suivantes.	NO Vi, Numatic erklærer herved under eget ansvar, at det ovennevnte produktet er i samsvar med følgende direktiver og standarder.	FI Me, Numatic täten vakutamme omalla vastuulla, että edellä mainittu tuote on yhdenmukainen seuraavien direktiivien ja standardien mukaisesti

2006/42/EC	Machinery Directive	EN60335-1:2012 + AC:2014 + A11:2014 + A13:2017 + A15:2021 EN60335-2-72:2012 EN62233:2008
2014/30/EU	EMC Directive	EN55014-1:2017 + A11:2020 EN55014-2:1997 + A1:2001 + A2:2008
2011/65/EU	RoHS Directive	

Authorised Signatory: Mr. Matthew Coles

Position: Head of Technology

Numatic International Limited
Chard,
Somerset, TA20 2GB, UK

Signed:  Date: 1st February 2024

This Machine Has Been Packed
With The Following

Brush / Pad

Floor Tool

Charging Lead

Battery

Fuse Pack

Signed

Distributed by:

Numatic

numatic.com

Numatic International Limited (Head Office)

Chard, Somerset TA20 2GB, UNITED KINGDOM
Tel: 01460 68600 numatic.com

Numatic International GmbH

Fränkische Straße 15-19, 30455 Hannover, DEUTSCHLAND
Tel: +49 (0) 511 984 2160 numatic.de

Numatic International Denmark

Fränkische Straße 15-19, 30455 Hannover, DEUTSCHLAND
Tel: +45 (0) 316 40808 numatic-online.dk

Numatic International S.A.S

13/17 rue du Valengelier, EAE la Tuilerie, 77500 Chelles, FRANCE
Tel: +33 (0) 164 726 161 numatic.fr

Numatic International BV

Vennootsweg 15, 2404 CG, Alphen aan den Rijn, NEDERLAND
Tel: +31 (0) 172 467 999 numatic.nl

Numatic International Schweiz AG.

Sihlbruggstrasse 3A, 6340 Baar, SCHWEIZ
Tel: +41 (0) 41 768 0760 numatic.ch

Numatic International (PTY) Ltd.

Cnr. 16th & Pharmaceutical Road, Randjes Park, Midrand 1685, SOUTH AFRICA
Tel: +27 (0) 861 686 284 numatic.co.za

Numatic International ULDA

Rua Francisco da Silva Duarte, nº79,
4475-269 Santa Maria de Avioso, Castêlo da Maia, PORTUGAL
Tel: +351 220 047 700 numatic.pt

Numatic International Spain, S.L.U.

Av. Baix Llobregat, 5-7, Oficina bajos 1 (Parc Negocis Mas Blau II)
08820 El Prat de Llobregat (Barcelona), SPAIN
Tel: +34 93 647 22 22 numatic.es

Numatic International Italy S.R.L

Via Luigi Galvani, 2, Z.I. Talponedo, 33080 Porcia (PN), ITALY
Tel: +39 (0) 434 046 211 numatic.it

This Product has been comprehensively inspected and checked during every stage of its manufacture.
Including an in-depth electrical safety and functionality test.